

TravelMate 3030/3040

Service Guide

Service guide files and updates are available on the AIPG/CSD web; for more information, please refer to <http://csd.acer.com.tw>

Revision History

Please refer to the table below for the updates made on TravelMate 3030/3040 service guide.

Date	Chapter	Updates

Copyright

Copyright © 2006 by Acer Incorporated. All rights reserved. No part of this publication may be reproduced, transmitted, transcribed, stored in a retrieval system, or translated into any language or computer language, in any form or by any means, electronic, mechanical, magnetic, optical, chemical, manual or otherwise, without the prior written permission of Acer Incorporated.

Disclaimer

The information in this guide is subject to change without notice.

Acer Incorporated makes no representations or warranties, either expressed or implied, with respect to the contents hereof and specifically disclaims any warranties of merchantability or fitness for any particular purpose. Any Acer Incorporated software described in this manual is sold or licensed "as is". Should the programs prove defective following their purchase, the buyer (and not Acer Incorporated, its distributor, or its dealer) assumes the entire cost of all necessary servicing, repair, and any incidental or consequential damages resulting from any defect in the software.

Acer is a registered trademark of Acer Corporation.

Intel is a registered trademark of Intel Corporation.

Pentium 4 and Celeron are trademarks of Intel Corporation.

Other brand and product names are trademarks and/or registered trademarks of their respective holders.

Conventions

The following conventions are used in this manual:

Screen messages	Denotes actual messages that appear on screen.
NOTE	Gives bits and pieces of additional information related to the current topic.
WARNING	Alerts you to any damage that might result from doing or not doing specific actions.
CAUTION	Gives precautionary measures to avoid possible hardware or software problems.
IMPORTANT	Reminds you to do specific actions relevant to the accomplishment of procedures.

Preface

Before using this information and the product it supports, please read the following general information.

1. This Service Guide provides you with all technical information relating to the BASIC CONFIGURATION decided for Acer's "global" product offering. To better fit local market requirements and enhance product competitiveness, your regional office MAY have decided to extend the functionality of a machine (e.g. add-on card, modem, or extra memory capability). These LOCALIZED FEATURES will NOT be covered in this generic service guide. In such cases, please contact your regional offices or the responsible personnel/channel to provide you with further technical details.
2. Please note WHEN ORDERING FRU PARTS, that you should check the most up-to-date information available on your regional web or channel. If, for whatever reason, a part number change is made, it will not be noted in the printed Service Guide. For ACER-AUTHORIZED SERVICE PROVIDERS, your Acer office may have a DIFFERENT part number code to those given in the FRU list of this printed Service Guide. You MUST use the list provided by your regional Acer office to order FRU parts for repair and service of customer machines.

Chapter 1	System Specifications	1
	Features	1
	System Block Diagram	3
	Board Layout	4
	Top View	4
	Bottom View	5
	Your Acer Notebook tour	6
	Front view	6
	Closed front view	7
	Left View	8
	Right View	8
	Rear View	9
	Bottom View	10
	Indicators	11
	Easy-Launch Buttons	12
	Touchpad	13
	Touchpad Basics	13
	Using the Keyboard	14
	Lock keys and Embedded Numeric Keypad	14
	Windows Keys	15
	Hotkeys	15
	Special Keys	17
	Acer Empowering Technology	18
	Empowering Technology password	18
	Acer ePower Management	18
	Acer ePresentation Management	20
	Acer eDataSecurity Management (for selected models)	21
	Acer eLock Management	23
	Acer eRecovery Management	24
	Acer eSettings Management	25
	Acer ePerformance Management	25
	Acer OrbiCam	26
	Using the System Utilities	30
	Acer GridVista (dual-display compatible)	30
	Launch Manager	31
	Hardware Specifications and Configurations	32
Chapter 2	System Utilities	41
	BIOS Setup Utility	41
	Navigating the BIOS Utility	42
	Information	43
	Main	45
	Advanced	47
	Security	49
	Boot	53
	Exit	54
	BIOS Flash Utility	55
	Remove HDD/BIOS Utility	56
Chapter 3	Machine Disassembly and Replacement	61
	General Information	62
	Before You Begin	62
	Disassembly Procedure Flowchart	63
	Removing the Battery Pack	64

Table of Contents

Removing the miniPCI/Memory/HDD Module/Keyboard	65
Removing the miniPCI and Memory	65
Removing the HDD	65
Removing the keyboard	65
Separate the LCD module and main unit	67
Disassemble the main unit	68
Separate upper and lower case	68
Removing the Bluetooth module	68
Removing the MDC module	68
Removing the audio module	69
Removing the mainboard from lower case	69
LCD module disassembly	71
HDD Disassembly and Reassembly	73
Chapter 4 Troubleshooting	75
System Check Procedures	76
External Diskette Drive Check	76
External CD-ROM Drive Check	76
Keyboard or Auxiliary Input Device Check	76
Memory check	76
Power System Check	77
Touchpad check	78
Power-On Self-Test (POST) Error Message	79
Index of Error Messages	80
Phoenix BIOS Beep Codes	82
Index of Symptom-to-FRU Error Message	86
Intermittent Problems	90
Undetermined Problems	91
Chapter 5 Jumper and Connector Locations	93
Top View	93
Bottom View	94
Chapter 6 FRU (Field Replaceable Unit) List	97
Exploded Diagram	98
FRU List	101
Appendix A Model Definition and Configuration	114
TravelMate 3030 Series	114
TravelMate 3040 Series	115
Appendix B Test Compatible Components	129
Microsoft® Windows® XP Pro Environment Test	130
Microsoft® Windows® XP Home Environment Test	132
Appendix C Online Support Information	135

System Specifications

Features

This computer was designed with the user in mind. Here are just a few of its many features:

Platform

Intel® Centrino® Duo mobile technology, featuring:

- ❑ Intel® Core™ 2 Duo processor T7200/T7400/T7600 (4 MB L2 cache, 2/2.16/2.33 GHz, 667 MHz FSB) or T5500/T5600 (2 MB L2 cache, 1.66/1.83 GHz, 667 MHz FSB), supporting Intel® Extended Memory 64 Technology (Intel® EM64T) (for TM3040 series)
- ❑ Intel® Core™ Duo processor T2300/T2400/T2500/T2600 (2 MB L2 cache, 1.66/1.83/2/2.16 GHz, 667 MHz FSB) (for TM3030 series)
- ❑ Intel® 945GM Express chipset
- ❑ Intel® PRO/Wireless 3945ABG network connection (dual-band tri-mode 802.11a/b/g) Wi-Fi CERTIFIED™ solution, supporting Acer SignalUp™ wireless technology

System memory

- ❑ DDRII 533/667 SDRAM
- ❑ Two DDR SODIMM slots
- ❑ Upgradeable to 4GB memory using two soDIMM modules (dual-channel support)

Display and graphics

- ❑ 12.1" WXGA high-brightness (200-nit) Acer CrystalBrite™ TFT LCD, 1280 x 800 pixel resolution, supporting simultaneous multi-window viewing via Acer GridVista™
- ❑ 12.1" WXGA TFT LCD, 1280 x 800 pixel resolution, supporting simultaneous multi-window viewing via Acer GridVista™
- ❑ Mobile Intel® 945GM Express chipset with integrated 3D graphics, featuring Intel® Graphics Media Accelerator (GMA) 950, up to 224 MB of shared system memory, supporting Microsoft® DirectX® 9.0, PCI Express®
- ❑ Dual independent display support
- ❑ 16.7 million colors
- ❑ MPEG-2/DVD hardware-assisted capability

Storage subsystem

- ❑ 80/100/120/160 GB Serial ATA hard disk drive with Acer DASP+ (Disk Anti-Shock Protection)
- ❑ External IEEE 1394 bus-powered optical drive:
 - ✦ DVD-Super Multi double-layer
 - ✦ DVD/CD-RW combo drive
- ❑ 5-in-1 card reader supporting Secure Digital (SD), MultiMediaCard (MMC), Memory Stick® (MS), Memory Stick PRO™ (MS PRO), xD-Picture Card™ (xD)

Audio

- Intel HD(High Definition) Audio
- S/PDIF (Sony/Philips Digital Interface) support for digital speakers
- Two built-in Acer 3DSonic stereo speakers (1.5W, 30CC)
- Built-in microphone
- Sound Blaster pro™ and MS-Sound compatible

Communication

- Acer Video Conference featuring Voice and Video over Internet Protocol (VVoIP) support via Acer OrbiCam and optional Acer Bluetooth® VoIP phone
- Acer OrbiCam integrated 1.3 megapixel CMOS Camera featuring:
 - ✦ 225-degree ergonomic rotation
 - ✦ Acer VisageON technology support
 - ✦ Acer PrimaLite technology support
- WLAN: Intel® PRO/Wireless 3945ABG network connection (dual-band tri-mode 802.11a/b/g) Wi-Fi CERTIFIED™ solution, supporting Acer SignalUp™ wireless technology
- WPAN: Bluetooth® 2.0+EDR (Enhanced Data Rate)
- LAN: Gigabit Ethernet; Wake-on-LAN ready
- Modem: 56K ITU V.92 with PTT approval; Wake-on-Ring ready

I/O Ports

- 124-pin Acer ezDock connector
- PC Card slot (one Type II)
- 5-in-1 card reader (MS/MS PRO/MMC/SD/xD)
- Three USB 2.0 ports
- IEEE 1394 port (6-pin)
- Fast Infrared (FIR) port
- External display (VGA) port
- Headphones/speaker/line-out jack with S/PDIF support
- Microphone/line-in jack
- Ethernet (RJ-45) port
- Modem (RJ-11) port
- DC-in jack for AC adaptor

Environment

Temperature:

- Operating: 5° C to 35° C
- Non-operating: -20° C to 65° C

Humidity (non-condensing):

- Operating: 20% to 80%
- Non-operating: 20% to 80%

Board Layout

Top View



1	PCMCIA Connector	12	Keyboard Connector
2	FIR	13	EC Controller
3	Modem Board Connector	14	MDC Connector
4	Audio Board Connector	15	SW Board Connector
5	Power/Charger LED	16	3V/5V Converter IC
6	Wireless Switch	17	LCD/CCD Connector
7	Bluetooth Switch	18	Touchpad Connector
8	Internal Microphone Connector	19	Battery Connector
9	Internal Speaker Connector	20	Charger IC
10	Bluetooth Cable Connector	21	+1.05V Converter IC
11	SATA HDD Connector		

Bottom View

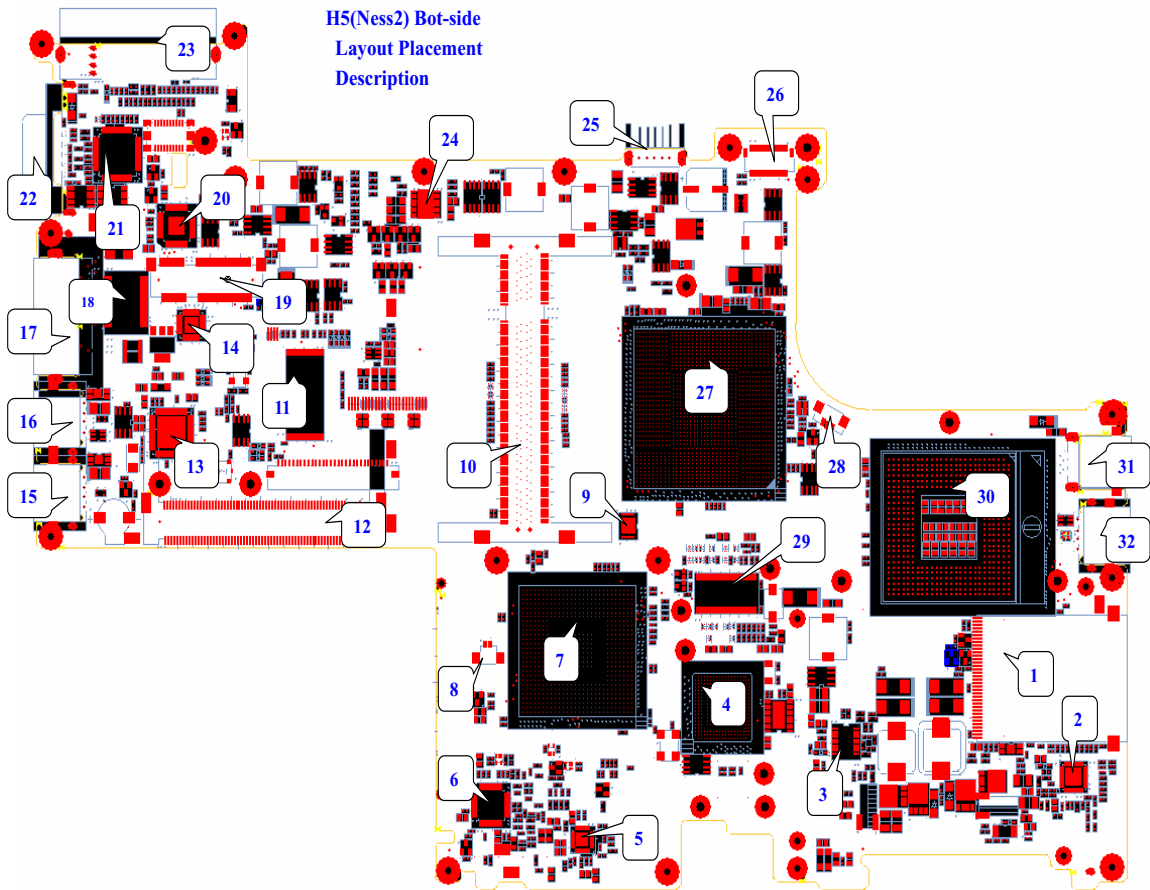

1	5-in1 Card Reader Connector	17	
2	CPU Power IC	18	
3	+1.5V Power IC	19	Mini Card Connector
4	Card Bus IC	20	DVI (CH7307C) IC
5	Audio AMP	21	SIO (PC87383) IC
6	Audio Codec AL883	22	VGA Connector
7	South Bridge ICH7-M	23	EZ dock Connector
8	RTC Battery	24	DDRII Power IC
9	G Sense	25	Battery Connector
10	DDRII soDIMM socket	26	DC-in Connector
11	BIOS	27	North Bridge 945GM
12	Mini PCI Connector	28	FAN Connector
13	LAN Controller	29	Clock Generator
14	LAN Switch	30	CPU
15	USB Connector	31	1394 Connector
16	USB Connector	32	USB Connector

Your Acer Notebook tour

After knowing your computer features, let us show you around your new TravelMate computer.







Front view

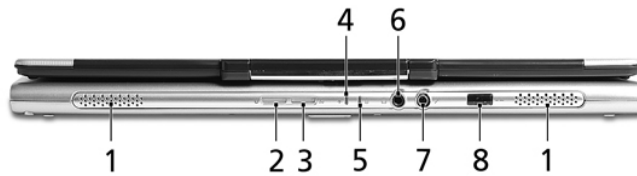

#	Item	Description
1	Camera	1.3 Mega Pixel CMOS video camera with 225 degree rotation feature.
2	Display screen	Also called Liquid-Crystal Display(LCD), displays computer output.
3	Easy-launch buttons	Buttons for launching frequently used programs.
4	Status indicators	Light-Emitting Diodes(LEDs) that light up to show the status of the computer's functions and components.
5	Palmrest	COMfortable support area for your hands when you use the computer.
6	CLick buttons(left, center and right)	The left and right buttons function like the left and right mouse buttons; the center button serves as a 4-way scroll button.
7	Touchpad	Touch-sensitive pointing device which functions like a computer mouse.
8	Microphone	Internal microphone for sound recording.
9	Keyboard	For entering data into your computer.
10	Power button	Turns the computer on and off.





Closed front view

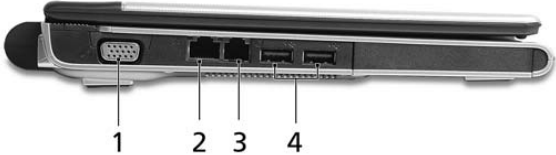

#	Icon	Item	Description
1	N/A	Speakers	Left and right speakers deliver stereo audio output.
2		Bluetooth communication button/indicator	Press to enable/disable Bluetooth function. Lights to indicate the status of Bluetooth communications.
3		Wireless communications button/indicator	Press to enable/disable Wireless function. Lights to indicate the status of wireless LAN communications. (manufacturing option)
4		Power indicator	Indicates the computer's power status.
5		Battery indicator	Indicates the computer's battery status.
6		Headphones/speaker/line-out jack with S/PDIF support	Connects to audio line-out devices(e.g., speakers, headphones)
7		Mic-in jack	Accepts inputs from external microphones.
8		Infrared port	Interfaces with infrared devices(for TravelMate 4270/4670 Series)

Left View







#	Icon	Item	Description
1		External display (VGA) port	Connects to display device(e.g., external monitor, LCD projector)
2		Ethernet(RJ-45) port	Connects to an Ethernet 10/100/1000 based network.
3		Modem(RJ-11) port	Connects to a phone line.
4		Two USB2.0 ports	Connect to USB 2.0 devices(e.g., USB mouse, USB camera)

Right View





#	Icon	Item	Description
1		PC Card slot	Accepts one Type II PC Card.

#	Icon	Item	Description
2		5-in-1 card reader	Accepts Secure Digital(SD), MultiMediaCard(MMC), Memory Stick(MS), Memory Stick Pro(MS PRO), and xD-Picture Card. Note:Only one card can operate at any given time.
3		PC Card slot eject button	Ejects the PC Card from the slot.
4		Two USB 2.0 ports	Connect to Universal Serial Bus (USB) 2.0 devices (e.g., USB mouse, USB camera).
5		IEEE 1394 port(6-pin)	Connects to IEEE 1394 devices
6		Ventilation slots	Enable the computer to stay cool, even after prolonged use.
7		Kensington lock slot	Connects to a Kensington-compatible computer security lock

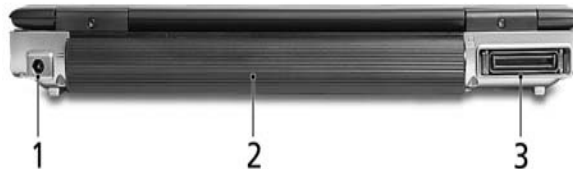
Rear View



#	Icon	Item	Description
1		DC-in Jack	Connects to an AC adapter.
2		Battery bay	Houses the computer's battery pack.
3		124-pin Acer ezDock connector	Connects to Acer ezDock(for TravelMate 4670 Series)

Bottom View









#	Item	Description
1	Battery bay	Houses the computer's battery pack.
2	Battery lock	Locks the battery in position.
3	Cooling fan	Helps keep the computer cool. Note: Do not cover or obstruct the opening of the fan.
4	Acer DASP+ (Disk Anti-Shock Protection)	Protects the hard disk drive from shocks and bumps.
5	Ventilation slots	Enable the computer to stay cool, even after prolonged use.
6	Memory compartment	Houses the computer's main memory
7	Battery release latch	Releases the battery to remove the battery pack.

Indicators

Your computer has seven easy-to-read status indicators, including four on the front panel.



The power, battery and wireless communication status indicators are visible even when the LCD display is closed.

Icon	Item	Description
	Caps Lock activity	Lights up when Caps Lock is activated.
	Num Lock activity	Lights up when Num Lock is activated.
	HDD	Indicate when the hard disk drive is active.
	Bluetooth	Indicates the status of Bluetooth communication.
	Wireless LAN	Indicates the status of wireless LAN communication.
	Power	Indicates the status of computer's power status.
	Battery	Indicates the computer's battery status. Note: The lights shows amber when the battery is charging. Note: The lights shows green when in AC mode.

Easy-Launch Buttons

Located above the keyboard are four buttons. They are mail, Web browser, Empowering Key and one user-programmable button.



Item	Default Application
Mail	Email application(User-programmable)
Web Browser	Internet browser(User -programmable)
	Acer Empowering Technology(User-programmable)
P	User programmable

Touchpad

The build-in touchpad is a pointing device that senses movement on its surface.

This means the cursor responds as you move your finger across the surface of the touchpad.

The touchpad is located in the middle of the palm rest area, providing maximum comfort and efficiency.

Touchpad Basics



- Move your finger across the touchpad(2) to move the cursor.
- Press the left (1) and right (4) buttons located beneath the touchpad to perform selection and execution functions. These two buttons are similar to the left and right buttons on a mouse. Tapping on the touchpad is the same as clicking the left button
- Use the 4-way scroll (3) button to scroll up or down and move left or right a page. This button mimics your cursor pressing on the right scroll bar of windows applications.

Function	Left Button(1)	Righ Button(4)	Main touchpad(2)	Center button(3)
Execute	Quickly click twice		Tap twice (at the same speed as double-clicking the mouse button)	
Select	Click once		Tap once	
Drag	Click and hold. Then slide your finger across the touchpad to drag the cursor over the selection.		Tap twice quickly; rest your finger on the touchpad on the second tap and drag the cursor.	
Access context menu		Click once		
Scroll				Click and hold to move up/down/left/right

NOTE: When using the touchpad, keep it-and your fingers-dry and clean. The touchpad is sensitive to finger movement; hence, the lighter the touch, the better the response. Tapping harder will not increase the touchpad's responsiveness.

Using the Keyboard

The full-sized keyboard includes an embedded numeric keypad, separate cursor keys, two Windows keys and twelve function keys.

Lock keys and Embedded Numeric Keypad

The keyboard has four lock keys which you can toggle on and off.



The computer features three lock keys, each with its own status indicator light.









Lock Key	Description
Caps Lock	When Caps Lock is on, all alphabetic characters are typed in uppercase. Toggle on and off by pressing the Caps Lock key on the left side of the keyboard.
Num lock <Fn+F11>	When Num Lock is on, the embedded keyboard is in numeric mode. The keys function as a calculator (complete with the arithmetic operators +, -, *, and /). Use this mode when you need to do a lot of numeric data entry. A better solution would be to connect and external keypad.
Scroll lock <Fn+F12>	When Scroll Lock is on, the screen moves one line up or down when you press the up or down arrow keys respectively. Scroll Lock does not work with some applications.

The embedded numeric keypad functions like a desktop numeric keypad. It is indicated by small characters located on the upper right corner of the keycaps. To simplify the keyboard legend, cursor-control key symbols are not printed on the keys.

Desired access	Num Lock on	Num Lock off
Numer keys on embedded keypad	Type numbers in a normal manner	
Cursor-control keys on embedded keypad	Hold <Shift> while using cursor-control keys.	Hold <Fn> while using cursor-control keys.
Main keyboard keys	Hold <Fn> while typing letters on embedded keypad.	Type the letters in a normal manner.

Windows Keys







The keyboard has two keys that perform Windows-specific functions.









<p>Windows logo key</p> 	<p>Pressed alone, this key has the same effect as clicking on the Windows Start button; it launches the Start menu. It can also be used with other keys to provide a variety of functions:</p> <ul style="list-style-type: none"> + Tab (Activates the next Taskbar button) + E (Opens the My Computer window) + F1 (opens Help and Support) + F (opens the Find: All Files dialog box). + R (Opens the Run dialog box). + M (minimizes all windows). <Shift> +  + M (undoes the minimize all windows action)
<p>Application key</p> 	<p>This key has the same effect as clicking the right mouse button; it opens the application's context menu.</p>

Hotkeys

The computer employs hotkeys or key combinations to access most of the computer's controls like screen brightness, volume output and the BIOS utility. To activate hotkeys, press and hold the <Fn> key before pressing the other key in the hotkey combination.



Hot Key	Icon	Item	Description
Fn+F1	?	Hot key help	This key will cause a help message to appear on the display device that describes the definition and functionality of the unit hot keys.
Fn+F2		Acer eSettings	Launches the Acer eSetting in Acer Empowering Technology. See “Acer Empowering Technology”
Fn+F3		Acer ePower Management	Launches the Acer ePower Management in Acer Empowering Technology. See “Acer Empowering Technology”
Fn+F4	z ^z	Sleep	Puts the computer in Sleep mode
Fn+F5		Display toggle	Switches display output between the display screen, external monitor(if connected)and both .
Fn+F6		Screen blank	Turns the display screen backlight off to save power. Press any key to return
Fn+F7		Touchpad toggle	Turns the internal touchpad on and off
Fn+F8		Speaker toggle	Turns the speakers on and off

Hot Key	Icon	Item	Description
Fn+ 		Volume up	Increases the sound volume
Fn+ 		Volume down	Decreases the sound volume
Fn+ 		Brightness up	Increases the screen brightness
Fn+ 		Brightness down	Decrease the screen brightness

Special Keys

You can locate the Euro symbol and the US dollar sign at the upper-center of your keyboard.

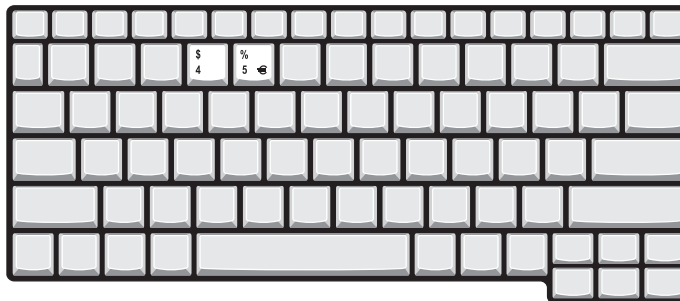

The Euro Symbol

1. Open a text editor or word processor.
2. Either press < € > at the bottom-right of the keyboard, or hold <Alt Gr> and then press the <5> key at the upper-center of the keyboard.

NOTE: Some fonts and software do not support the Euro symbol. Please refer to www.microsoft.com/typography/faq/faq12.htm for more information.

The US Dollar Sign

1. Open a text editor or word processor.
2. Either press < \$ > at the bottom-right of the keyboard, or hold <Shift> and then press the <4> key at the upper-center of the keyboard.

NOTE: This function varies according to the language settings.

Acer Empowering Technology

Acer's innovative Empowering Technology makes it easy for you to access frequently used functions and manage your new Acer notebook. It features the following handy utilities:

- ❑ **Acer eNet Management** hooks up to location-based networks intelligently.
- ❑ **Acer ePower Management** extends battery power via versatile usage profiles.
- ❑ **Acer ePresentation Management** connects to a projector and adjusts display settings conveniently.
- ❑ **Acer eDataSecurity Management (for selected models)** protects data with passwords and advanced encryption algorithms.
- ❑ **Acer eLock Management (for selected models)** limits access to external storage media.
- ❑ **Acer eRecovery Management** backs up and recovers data flexibly, reliably and completely.
- ❑ **Acer eSettings Management** accesses system information and adjusts settings easily.
- ❑ **Acer ePerformance Management** improves system performance by optimizing disk space, memory and registry settings.



For more information, press the < *e* > key to launch the Empowering Technology menu, then click on the appropriate utility and select the Help or Tutorial function.

Empowering Technology password

Before using Acer eLock Management and Acer eRecovery Management, you must initialize the Empowering Technology password. Right-click on the Empowering Technology toolbar and select "Password Setup" to do so. If you do not initialize the Empowering Technology password, you will be prompted to do so when running Acer eLock Management or Acer eRecovery Management for the first time.

Acer ePower Management

Acer ePower Management features a straightforward user interface. To launch it, select Acer ePower Management from the Empowering Technology interface.

AC Mode (Adapter mode)

The default setting is "Maximum Performance." You can adjust CPU speed, LCD brightness and other settings, or click on buttons to turn the following functions on/off: Wireless LAN, Bluetooth, CardBus, FireWire (1394), Wired LAN and Optical Device if supported.

DC Mode (Battery mode)

There are four pre-defined profiles - Entertainment, Presentation, Word Processing, and Battery Life. You can also define up to three of your own.

To create new power profile

1. Change power settings as desired.
2. Click "Save as..." to save to a new power profile.
3. Name the newly created profile.
4. Select whether this profile is for Adapter or Battery mode, then click OK.
5. The new profile will appear in the profile list.

Battery status

For real-time battery life estimates based on current usage, refer to the panel on the lower left-hand side of the window.



For additional options, click **Settings** to:

- Set alarms.
- Re-load factory defaults.
- Select what actions will be taken when the cover is closed or the power button is pressed.
- View information about Acer ePower Management.



Acer ePresentation Management

Acer ePresentation Management lets you project your computer's display to an external device or project using the hot key: Fn + F5. If auto-detection hardware is implemented in the system, your system display will be automatically switched out when an external display is connected to the system.



Acer eDataSecurity Management (for selected models)

Acer eDataSecurity Management is handy file encryption utility that protects your files from being accessed by unauthorized persons. It is conveniently integrated with Windows explorer as a shell extension for quick and easy data encryption/decryption and also supports on-the-fly file encryption for MSN Messenger and Microsoft Outlook.

The Acer eDataSecurity Management setup wizard will prompt you for a supervisor password and default encryption. This encryption will be used to encrypt files by default, or you can choose to enter your own file-specific password when encrypting a file.

NOTE: The password used to encrypt a file is the unique key that the system needs to decrypt it. If you lose the password, the supervisor password is the only other key capable of decrypting the file. If you lose both passwords, there will be no way to decrypt your encrypted file! **Be sure to safeguard all related passwords!**

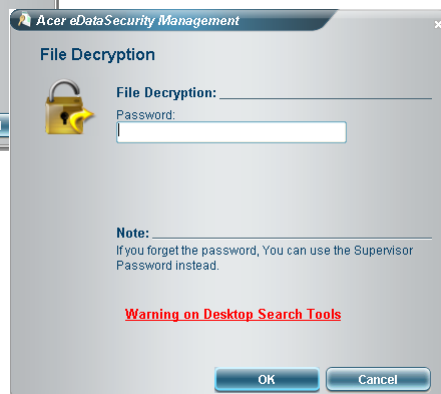
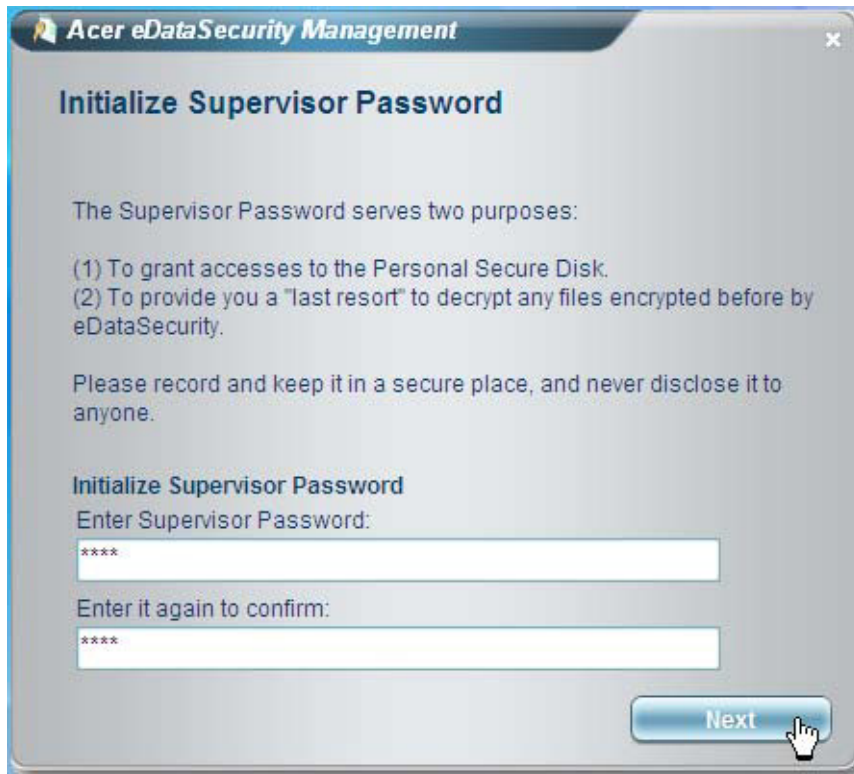

Acer eLock Management

Acer eLock Management is a security utility that allows you to lock your removable data, optical and floppy drives to ensure that data can't be stolen while your notebook is unattended.

- Removable data devices - includes USB disk drives, USB pen drives, USB flash drives, USB MP3 drives, USB memory card readers, IEEE 1394 disk drives and any other removable disk drives that can be mounted as a file system when plugged into the system.
- Optical drive devices - includes any kind of CD-ROM or DVD-ROM drives.
- Floppy disk drives - 3.5-inch disks only.
- Interfaces - includes serial ports, parallel port, infrared (IR), and Bluetooth.

To activate Acer eLock Management, a password must be set first. Once set, you can apply locks to any of the devices. Lock(s) will immediately be set without any reboot necessary, and will remain locked after rebooting, until unlocked.

NOTE: If you lose your password, there is no method to reset it except by reformatting your notebook or taking your notebook to an Acer Customer Service Center. Be sure to remember or write down your password.

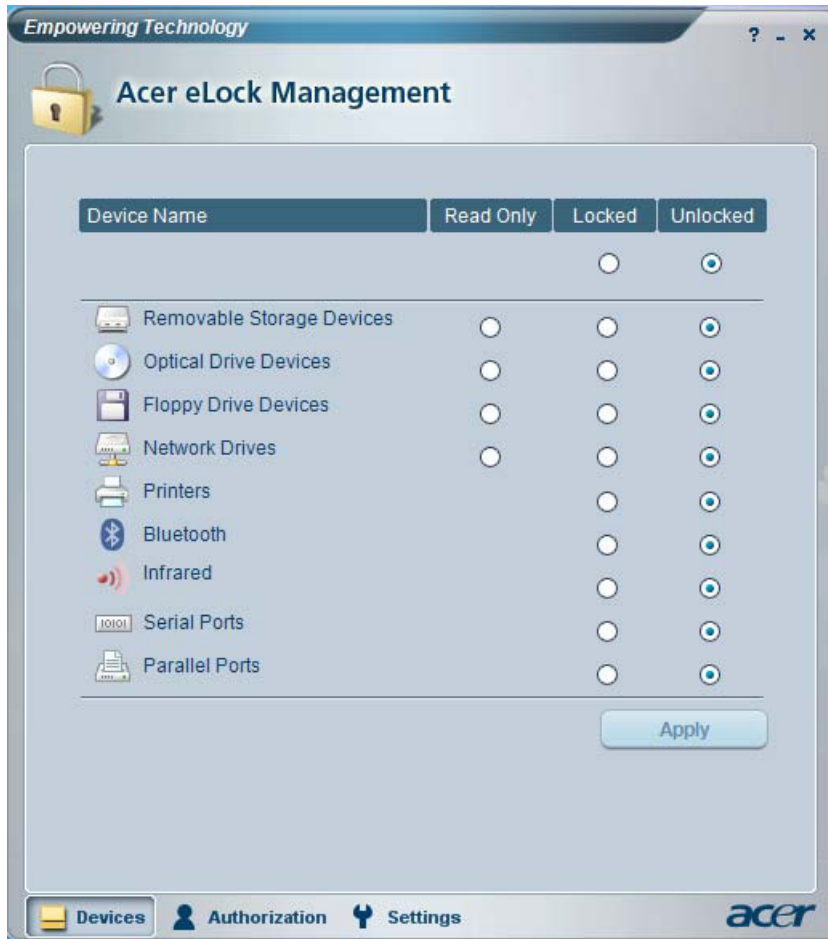

Acer eRecovery Management

Acer eRecovery Management is a powerful utility that does away with the need for recovery disks provided by the manufacturer. The Acer eRecovery Management utility occupies space in a hidden partition on your system's HDD. User-created backups are stored on D:\ drive. Acer eRecovery Management provides you with:

- Password protection.
- Recovery of applications and drivers.
- Image/data backup:
 - Back up to HDD (set recovery point).
 - Back up to CD/DVD.
- Image/data recovery tools:
 - Recover from a hidden partition (factory defaults).
 - Recover from the HDD (most recent user-defined recovery point).
 - Recover from CD/DVD.



For more information, please refer to “Acer eRecovery Management”

NOTE: If your computer did not come with a Recovery CD or System CD, please use Acer eRecovery Management’s “System backup to optical disk” feature to burn a backup image to CD or DVD. To ensure the best results when recovering your system using a CD or Acer eRecovery Management, detach all peripherals (except the external Acer ODD, if your computer has one), including your Acer ezDock.

Acer eSettings Management

Acer eSettings Management allows you to inspect hardware specifications and to monitor the system health status. Furthermore, Acer eSettings Management enables you to optimize your Windows operating system, so your computer runs faster, smoother and better.

Acer eSettings Management also:

- Provides a simple graphical user interface for navigating.
- Displays general system status and advanced monitoring for power users.



Acer ePerformance Management

Acer ePerformance Management is a system optimization tool that boosts the performance of your Acer notebook. It provides an express optimization method to release unused memory and disk space quickly. The user can also enable advanced options for full control over the following option:

- Memory optimization - releases unused memory and check usage.
- Disk optimization - removes unneeded items and files.
- Speed optimization - improves the usability and performance of your Windows XP system.

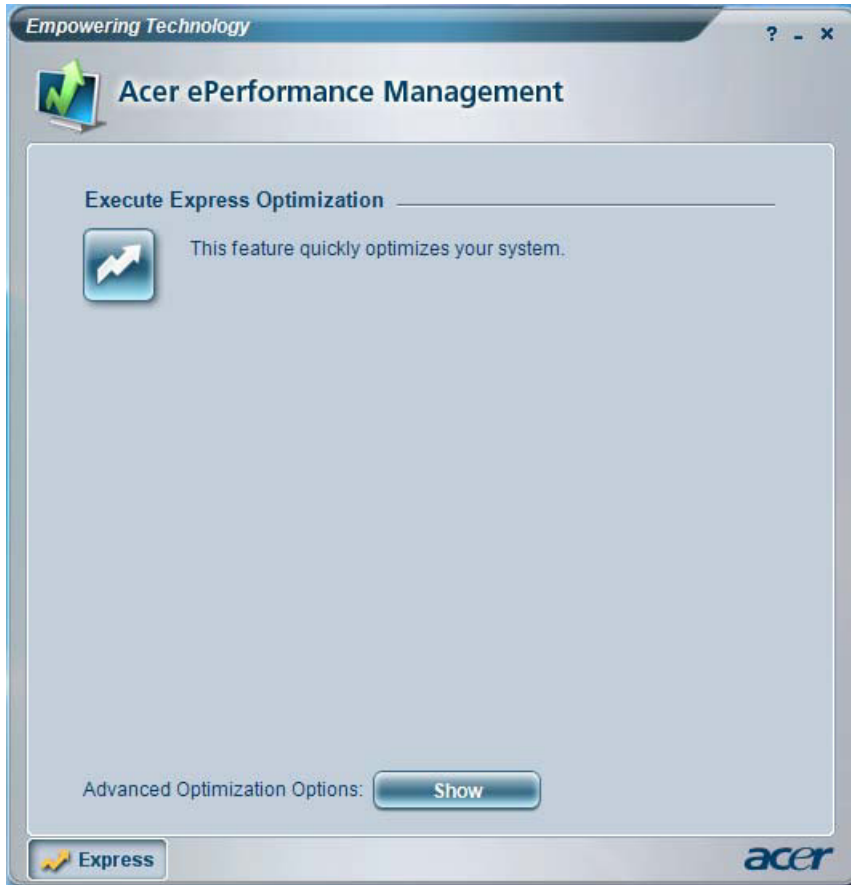

Acer OrbiCam

The Acer OrbiCam is a 1.3 megapixel CMOS camera appropriately mounted on the top of the LCD panel. The camera's 225-degree ergonomic rotation allows you to capture high-resolution photos or videos up front or at the back of the LCD panel. The Acer OrbiCam fully supports the Acer Video Conference technology so that you can transmit the best video quality over an instant Messenger service.

Getting to know your Acer OrbiCam

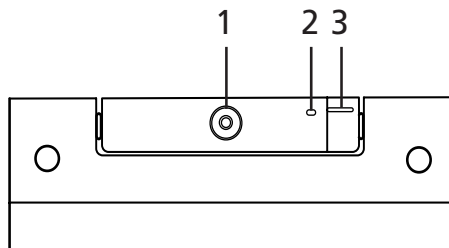

No.	Item
1	Lens

No.	Item
2	Power indicator
3	Rubber grip (selected models only)

Rotating the Acer Orbicam

The Acer Orbicam rotates 225 degrees counterclockwise to achieve the desired angle. Refer to the illustrations below:

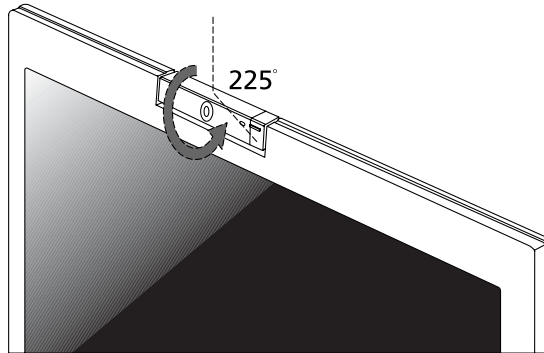

For your convenience, the camera snaps 45 degrees to match the position of your face in front or at the back of the LCD panel.

NOTE: Do not rotate the camera clockwise to prevent damage to the device.

Launching the Acer Orbicam

To launch the Acer Orbicam, double click on the Acer Orbicam icon on the screen.

OR

Click Start > All programs > Acer > Acer Orbicam. The Acer Orbicam capture windows window appears.

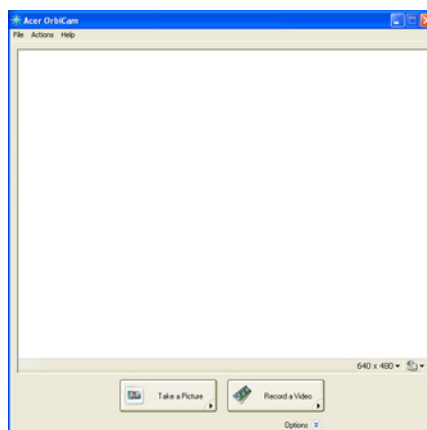

Changing the Acer Orbicam settings

Resolution

To change the capture resolution, click the displayed resolution at the bottom right corner of the capture window, then select the desired resolution.

Options

Click Options to display the Window, Preview, and Folder tabs. Use the options to change the capture window size, preview settings, and the folder for captured photos or videos.

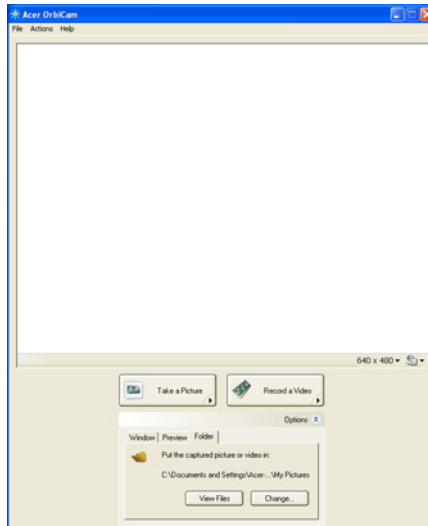

Camera Settings

- ❑ **Basic settings:** Click the Camera Settings icon on the bottom right corner of the capture display, then select Camera Settings from the pop-up menu. You can adjust the Video, Audio, and Zoom/Face tracking options from this window.



- ❑ **Capture settings:** From the Camera Settings window, click the Driver Settings button. The Properties window will appear.

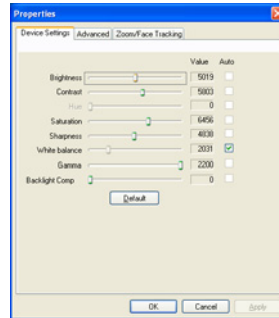

- Device Settings allows you to change the camera brightness, contrast, hue, saturation, sharpness, etc.
- Advanced Settings allows you to achieve gain control, implement image mirror, select image enhancements and anti-flicker settings, and turn on/off the camera indicator.
- Zoom/Face Track Settings allows you to adjust the zoom level and turn the face tracking feature on or off.

Capturing photos or videos

To capture a photo or a video clip, rotate the Acer OrbiCam to get the desired angle, then click the Take a Picture or Record a Video button. The Windows Picture and Fax Viewer or the Windows Media Player automatically launches to display or play a preview of the photo/video clip.

NOTE: By default, all photos and videos are saved in the My Pictures and My Videos folder.

Using the Acer OrbiCam as webcam

The Acer OrbiCam is automatically selected as the capture device of any instant messenger (IM) application. To use the Acer OrbiCam as a webcam, open the IM service, then select the video/webcam feature. You can now broadcast from your location to an IM partner anywhere in the world.

Using the System Utilities

NOTE: The system utilities work under Microsoft Windows XP only.

Acer GridVista (dual-display compatible)

NOTE: This feature is only available on certain models.

To enable the dual monitor feature of the notebook, first ensure that the second monitor is connected, then select **Start, Control Panel, Display** and click on **Settings**. Select the secondary monitor (2) icon in the display box and then click the check box **Extend my windows desktop onto this monitor**. Finally, click **Apply** to confirm the new settings and click **OK** to complete the process.

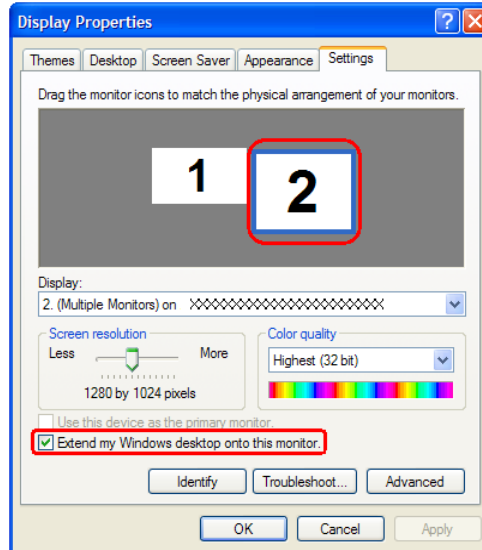

Acer GridVista is a handy utility that offers four pre-defined display settings so you can view multiple windows on the same screen. To access this function, please go to **Start>All Programs** and click on **Acer GridVista**. You may choose any one of the four display settings indicated below:



Double (verticle), Triple (primary at left), Triple (primary at right), or Quad Acer Gridvista is dual-display compatible, allowing two displays to be partitioned independently.

Acer Gridvista is dual-display compatible, allowing two displays to be partitioned independently.

AcerGridVista is imple to set up:

1. Run Acer GridVista and select your preferred screen configuration for each display from the task bar.
2. Drag and drop each window into the appropriate grid.
3. Enjoy the convenience of a well-organized desktop.

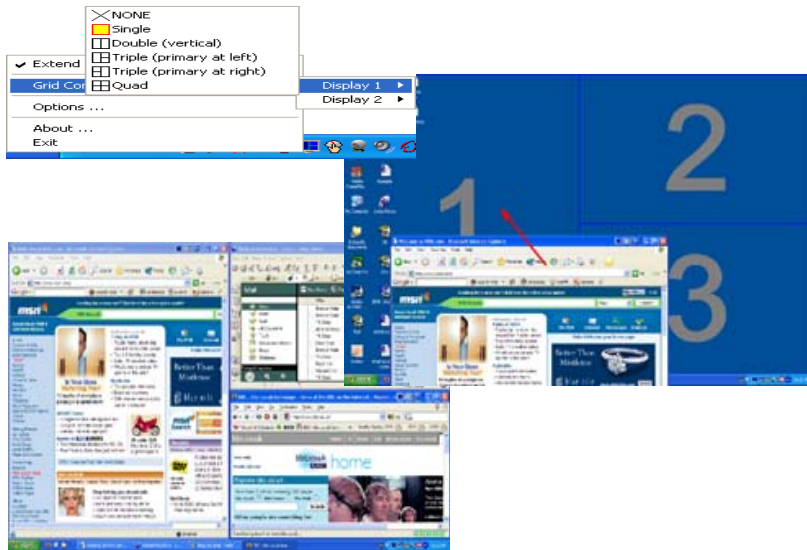

NOTE: Please ensure that the resolution setting of the second monitor is set to the manufacturer's recommended value.

Launch Manager

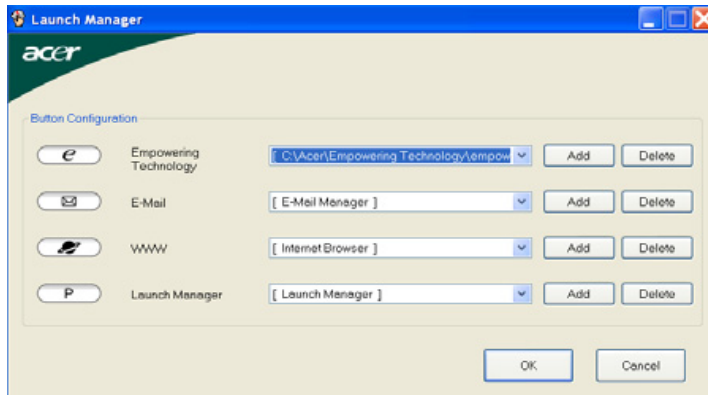

Launch Manager allows you to set the four easy-launch buttons located above the keyboard. You can access the Launch Manager by clicking on Start > All Programs > Launch Manager to start the application.

Hardware Specifications and Configurations

Processor

Item	Specification
CPU type	Intel® Core™ 2 Duo processor T7200/T7400/T7600 (4 MB L2 cache, 2/2.16/2.33 GHz, 667 MHz FSB) or T5500/T5600 (2 MB L2 cache, 1.66/1.83 GHz, 667 MHz FSB), supporting Intel® Extended Memory 64 Technology (Intel® EM64T) (for TM3040 series) Intel® Core™ Duo processor T2300/T2400/T2500/T2600 (2 MB L2 cache, 1.66/1.83/2/2.16 GHz, 667 MHz FSB) (for TM3030 series)
CPU package	479-pin uFC-PGA socket
CPU core voltage	VCC_Core (based on CPU) VCCA 1.5A VCCP 1.05V
CPU I/O voltage	1.2875V

System Board Major Chips

Item	Specification
System core logic	Intel® 945GM/ICH7M
Super I/O controller	NS 87383, LPC interface
Audio controller	Azalia Audio Controller ALC883D
Video controller	UMA
Hard disk drive controller	ICH7M
Keyboard controller	NS 97551
IrDA controller	NS 87383
DVI controller	CH7307
PCMCIA/ card reader / 1394 controller	TI PCI7412
DDR-soDIMM controller	945GM

CPU Fan True Value Table

DTS(degree C)	Fan Speed (rpm)	Acoustic Level (dBA)
45-50	0-3000	29
55-66	0-3300	33
68-74	3300-3800	38
78-83	3800-4100	40
86-91	4100-4800	40

Throttling 50%: On= 99° C; OFF=93° C

OS shut down at 105° C; H/W shot down at 110° .

BIOS

Item	Specification
BIOS vendor	PhneoiX
BIOS Version	1.00 (MP version)
BIOS ROM type	SST39VF080
BIOS ROM size	1M byte FLASH ROM SST
BIOS package	40-pin TSOP (10mmx20mm)
Supported protocols	ACPI 1.0b/2.0/3.0 compliance, PCI 2.2, System/HDD Password Security Control, INT 13H Extensions, PnP BIOS 1.0a SMBIOS 2.4, BIOS Boot Specification, Simple Boot Flag 1.0, Boot Block, PCI Bus Power Management Interface Specification, USB Specification 1.1/2.0, IEEE 1394 1.0, USB/1394 CD-ROM Boot Up support, PC Card Standard 1995 (PCMCIA 3.0 Compliant Device), IrDA 1.0, Intel AC97 CNR Specification, WfM 2.0, PXE 2.1, Boot Integrity Service Application Program Interface (BIS) 1.0, PC99a and Mobile PC2001 Compliant
BIOS password control	Set by setup manual

System Memory

Item	Specification
Memory controller	945GM
Memory size	256MB/512MB/1G
DIMM socket number	2
Supports memory size per slot	1024 MB
Supports maximum memory size	2GB (with dual soDIMM modules)
Supports DIMM type	DDRII SDRAM Standard
Supports DIMM Speed	533/667 MHz
Supports DIMM voltage	1.8V
Memory module combinations	You can install memory modules in any combinations as long as they match the above specifications.

Wireless LAN

Item	Specification
Card Type	Mini-card
Mode	802.11 a/b/g(Mini-Card)
Antenna	Built in 2 antenna(Has to be placed on the top of LCD on the sides of LCD latch)
Support	Wi-Fi, WPA2, WMM, CCX V3/V4

Modem Interface

Item	Specification
Data modem data baud rate (bps)	56K ITU
Supports modem protocol	V.90/V.92, WWDA Apply CISPR22 Wake-on-Ring ready

Modem Interface

Item	Specification
Modem connector type	RJ11

VGA

Notice	UMA
Chipset for suitable VGA type	built-in 945GM
Video RAM	up to 224MB of shared system memory

USB Port

Item	Specification
USB compliancy level	2.0
OHCI	USB 2.0
Number of USB port	3
Location	Left Side *2 Right Side *1

Audio Port

Item	Specification
Audio Controller	Azalia Audio Controller (Realtek ALC883)
Audio onboard or optional	Built-in
Mono or Stereo	Stereo
Resolution	SNR>85, High-performance DACs with 95dB SNR, ADCs 85 dB SNR
Compatibility	Microsoft PC99/2100, AC97 2.3 & WHQL/WLP2.0
Mixed sound source	CD
Sampling rate	All DACs support 44.1K/48K/96K/192K sample rate All ADCs support 44.1K/48K/96K sample rate
Internal microphone	one internal microphone(2 digital microphone array)
Internal speaker / Quantity	Yes / 2(at least 1.5W/30cc for each)
Support	VoIP/Universal jack

PCMCIA Port

Item	Specification
PCMCIA controller	PCI7412
Supports card type	Type II
Number of slots	One
Access location	Right Side
Supports 32 bit CardBus	Yes

Keyboard

Item	Specification
Keyboard controller	NS PC97551

Keyboard

Item	Specification
Keyboard vendor & model name	New Acer Ergo keyboard
Total number of keypads	88-89 keys Acer Fine Touch™ keyboard
Touchpad with 4-way integrated scroll button	Yes
Feature	<input type="checkbox"/> Support Windows keys and application keys <input type="checkbox"/> Standard pitch, 2.5 mm travel length <input type="checkbox"/> Hotkey controls <input type="checkbox"/> embedded numeric keypad <input type="checkbox"/> Multi-Langue support <input type="checkbox"/> Spill-proof
Four easy-launch buttons	<input type="checkbox"/> Internet browser <input type="checkbox"/> email with LED <input type="checkbox"/> Empowering key <input type="checkbox"/> one user-programmable button

Battery

Item	Specification
Vendor & model name	Panasonic/Sanyo
Battery Type	Li-ion
Number of battery cell	6-cell 2400mAh 3-cell 2000mAh
Package configuration	
Pin 1 Pin 2	BATT+: Battery+, Battery Positive Terminal
Pin 3	ID : Identify Pin (Note 1)
Pin 4	B/I : Battery-In Pin
Pin 5	TS : Connect to Thermister
Pin 6	SMD : SMBus data interface I/O pin
Pin 7	SMC : SMBus clock interface I/O pin
Pin 8 Pin 9	GND : Battery Negative Terminal

12.1" LCD Panel

Item	Specification		
Vendor & model name	AUO B121EW01 V3 AUO B121EW02 V5	QDI QD12TL02-01/ QD12TL02-02	CMO N121 3-L 01/ N121 3-L02
Screen Diagonal (mm)	12.1" WXGA	12.1" WXGA	12.1" WXGA
Active Area (mm)	261.12(W)163.2(H)	261.12(W)x163(H)	261.12(H)x163.2(V)
Display resolution (pixels)	1280x3(RGB)x800	1280x800	1280xRGBx800
Pixel Pitch(mm)	0.204(per on triad)x0.204	0.2055(W)x0.2055(H)	0.204x0.204
Pixel Arrangement	RGB vertical stripe	RGB vertical stripe	RGB vertical stripe
Display Mode	Normally white	Normally white	Normally white

12.1" LCD Panel

Item	Specification		
Surface Treatment	Hard coating(3H) glare type/anti-glare type	Hard coating(3H) glare type/anti-glare type	Hard coating(3H) glare type/anti-glare type
Typical White Luminance (cd/m ²) also called Brightness	180(Typical)	200(Center Typical)	200(Typical)
Contrast Ratio	400 :1(Min)	300:1(Min)	500(Typical)
Response Time (Optical Rise Time+Fall Time)msec	25(Typical) 35(Max)	50(Max)	25(Typical) 35(Max)
Normal Input Voltage of Power Supply	+3.3V(Typical)	+3.3V(Typical)	+3.3V(Typical)
Power Consumption (watt)	4.5(Typical)	4.8(Typical)	3.66(typ) IL=6.0
Weight	280g (0.5mm glass)	250g	260(Typical)
Physical Size(mm)	275.82(H)x178(V)x5.2(D) (Max)	275.82(H)x178(V)x5.2(D)(Max)	275.8(H)x178(V)x4.9(D)(Typical)
Electrical Interface	1 channel LVDS	LVDS interface system(H-Sync, V-Sync)	3.3V LVDS with 1 pixel/clock
Support Color	Native 262K colours	256K colors	Native 262K colours
Viewing Angle (degree) Horizontal: Right/Left Vertical: Upper/Lower	40/40 10/30	45/45 15/35	45/45 20/45
Temperature Range(° C) Operating Storage (shipping)	0 to +50 -40 to +60	0 to +50 -25 to +60	0 to +50 -25 to +60

Item	Specification
Vendor & model name	LITEON-65W, PA-1650-02 QY YELLOW 1.7X5.5X11 LF
Input Requirements	
Maximum input current (A, @100Vac, full load)	1.6A @100Vac input and maximum load
Nominal(Rated) frequency (Hz)	50 or 60 and single phase
Frequency variation range (Hz)	47 - 63
Nominal voltages (Vrms)	100-127(low range) 200-240(high range)
Efficiency	High efficiency 83% minimum, full load, warm-up condition.
Output Ratings (CV mode)	
Rated output voltage	Offers rated output voltage 19.0V
Voltage Range	18.05V to 19.95V
Noise + Ripple	380mV
Rated Power	65Watts continuously at all specified conditions
Output current	0 A (min.) to 4.74A (max.)
Dynamic Output Characteristics	
Start-up time	Shall less than 5 sec

Item	Specification
Hold up time	at least 5ms (@115 Vac input, full load)
Over Voltage Protection (OVP)	29V
Over Current Protection(OCP)	Output current limit is 5A(Max mode)
Short circuit protection	Output can be shorted without damage, and auto recovery
Electrostatic discharge (ESD)	15kV (at air discharge) 8kV (at contact discharge)
Dielectric Withstand Voltage	
Primary to secondary	2150VDC for 1 sec
Leakage current	less than 100uA
Regulatory Requirements	1. CISPR 22 Class B 2. VCCI Class II

Hard Disk Drive Interface

Item	Specification		
Vendor & Model Name	Segate SATAST98823AS/ HGST SATA 1.5G NCQ MORAGA+HTS541080G9SA 00	Segate SATA ST9100824AS LF/HGST NCQMORAGA+HTS541010 G9SA00	Segate SATA ST9120821AS LF/ Toshiba SATA1.5G W/ NCQ MK1234GSX
Capacity (MB)	80000	100000	120000
Bytes per sector	1024/512	512	512
Data heads	3/4	4	4
Drive Format			
Disks	2	2	2
Spindle speed (RPM)	5400 RPM	5400 RPM	5400 RPM
Performance Specifications			
Buffer size	8192KB	8192KB	8192KB
Interface	Serial ATA	Serial ATA	Serial ATA
Max. media transfer rate (disk-buffer, Mbytes/s)	57.6/61.6	57.6/61.6	57.6
Data transfer rate (host~buffer, Mbytes/s)	150 MB/Sec. SATA 1.0	150 MB/Sec.	150 MB/Sec.
DC Power Requirements			
Voltage tolerance	5V(DC) +/- 5%	5V(DC) +/- 5%	5V(DC) +/- 5%

8X DVD Dual Interface

Item	Specification	
Vendor & model name	Lite-On SOSW-833S	PANASONIC UJ-840
Performance Specification		
Transfer rate (KB/sec)		
(1) Read	DVD-ROM(single layer) : 1.7-4X, 2.5-6X, 3.3-8X(CAV) DVD-ROM(dual layer) : 1.7-4X, 2.5-6X(CAV) DVD+R : 1X,2.4X(CLV) / 1.7-4X, 2.5-6X, 3.3-8X(CAV) DVD+RW : 1X, 2.4X(CLV) / 1.7-4X, 2.5-6X(CAV) Double layer DVD+R: 1X, 2.4X(CLV) / 1.7-4X(CAV) Double layer DVD-R: 1X, 2.4X(CLV) / 1.7-4X(CAV) DVD-R : 1X, 2X / 1.7-4X, 2.5-6X, 3.3-8X(CAV) DVD-RW : 1X, 2X / 1.7-4X, 2.5-6X(CAV) CD-ROM, Finalized CD-R, CD-RW : Data/CD-DAE/Video CD : 4.1-10X, 6.2-15X, 8.3-20X, 10-24X Unfinalized CD-R/RW : 4X/8X(CLV)	DVD-ROM : MAX 8X CAV CD-ROM : MAX 24X CAV
(2) Write	CD-R : 10X, 24X Low speed CD-RW: 4X High Speed CD-RW : 4X, 10X Ultra Speed CD-RW : 10X, 24X DVD+R : 2.4X, 4X, 6X, 8X DVD+R DL : 2.4X DVD+RW : 2.4X, 4X DVD-R : 2X, 4X, 6X, 8X DVD-RW : 2X, 4X	CD-R : Max 24X Zone CLV CD-RW : 4X CLV High Speed CD-RW : 10X CLV Ultra Speed CD-RW : 10X CLV DVD+R : Max 8X Zone CLV DVD+R DL : 2.4X CLV DVD+RW : Max. 4X Zone CLV DVD-R : Max. 8X Zone CLV DVD-RW : Max. 4X Zone CLV
(3) ATAPI Interface PIO mode DMA mode Ultra DMA mode	16.6MB/s: PIO mode4 16.6MB/s: Multi word mode2 33.3MB/s: Ultra DMA mode2	16.6MB/s: PIO mode4 16.6MB/s: Multi word mode2 33.3MB/s: Ultra DMA mode2
Buffer Memory	2MB	2MB
Interface	ATA/ATAPI-6, MMC-4	Enhanced IDE(ATAPI) compatible
Applicable disc format	CD-DA, CD-TEXT, CD ROM Mode-1, CD-ROM/XA Mode-2 Form-1 Form-2, CD-I Ready, Video-CD (MPEG-1), Photo-CD, Enhance CD, CD extra, I-Trax CD and UDF, DVD-ROM, DVD-Video, DVD-Video, DVD-R single/multi border(s), DVD+R single/multi session(s), DVD-RW, DVD+RW	DVD: DVD-VIDEO,DVD-ROM, DVD-R(3.9GB, 4.7GB), DVD-RW (Ver1.1) DVD+R, DVD+R DL, DVD+RW CD: CD-Audio, CD-ROM, CD-R/RW CD-ROM XA, , PhotoCD (Single and Multi Session), Video CD, CD-Extra (CD+), , CD-Text, Hybrid SACD
Loading mechanism	Load: Manual load/DC brushless motor system	Load: Manual Release: (a) Electrical Release
Power Consumption	Max. 1500 mA	Max. 1800 mA
Input Voltage	5 V +/- 5 % (Operating)	5 V +/- 5 % (Operating)

Combo Drive Interface

Item	Specification	
Vendor & model name	LITEON SOSC-2483K	PANASONIC UJDA-770
Performance Specification		
Transfer rate (KB/sec)(DVD)	Sustained: Max 10.1Mbytes/sec	Sustained: Max 10.8Mbytes/sec
Access Time(Typical)	DVD: Random Access: 100 ms DVD:Full Stroke: 190 ms	DVD: Typical:180 ms
Buffer Memory	2MB	2MB
Interface	Compliant to ATA/ATAPI-5, MMC-3	ATAPI interface
Applicable disc format	CD-DA, CD ROM Mode-1, CD-ROM/XA Mode-2 Form-1 and Form-2, CD-I Ready, Video-CD(MPEG-1), Karaoke-CD, Photo-CD, Enhance CD, CD extra, I-Trax CD and UDF	CD: CD-DA, CD-ROM, CD-R, CD-RW, CD-ROM XA, PhotoCD(MultiSession) DVD: DVD-ROM, DVD-Video, DVD-RAM(2.6GB/4.7GB), DVD-R, DVD-RW(Ver1.1), DVD+R, DVD+RW
Loading mechanism	Load: Manual load/DC brushless motor system	Load: Manual
Power Requirement		
Input Voltage	5 V +/- 5 % (Operating)	5 V +/- 5 % (Operating)

Power Management

ACPI Mode	Power Management
Mech. Off (G3)	All devices in the system are turned off completely.
Soft Off (G2/S5)	OS initiated shutdown. All devices in the system are turned off completely.
Working (G0/S0)	Individual devices such as the CPU and hard disk may be power managed in this state.
Sleeping State (S3)	CPU Power Down VGA Power Down PCMCIA Suspend Audio Power Down Hard Disk Power Down Super I/O Power Down
Sleeping State (S4)	Also called Hibernate state. System saves all system states and data onto the disk prior to power off the whole system.

Dimensions and Weight

Item	Details	
Model	Aspire 1690	Aspire 3510
Demimensions	297.5mm(W) x 210mm(D) x 24.5mm(H)	

Dimensions and Weight

Item	Details	
Model	Aspire 1690	Aspire 3510
Weight	<1650g (12.1"/6-cell w/ Camera) <1500g (12.1"/3-cell w/ Camera)	

Environmental Requirements

Item	Specification
Temperature	
Operating	+5 ~ +35°C
Non-operating	-20 ~ +65°C (storage package)
Humidity	
Operating	20% ~ 80% without condensation
Altitude	Operating sea level 0 to 10,000ft
	Storage sea level 0 to 40,000ft

System Utilities

BIOS Setup Utility

The BIOS Setup Utility is a hardware configuration program built into your computer's BIOS (Basic Input/Output System).

Your computer is already properly configured and optimized, and you do not need to run this utility. However, if you encounter configuration problems, you may need to run Setup. Please also refer to Chapter 4 Troubleshooting when problem arises.

To activate the BIOS Utility, press **F2** during POST (when "Press <F2> to enter Setup" message is prompted on the bottom of screen).

Press **F2** to enter setup. The default parameter of F12 Boot Menu is set to "disabled". If you want to change boot device without entering BIOS Setup Utility, please set the parameter to "enabled".

Press <F12> during POST to enter multi-boot menu. In this menu, user can change boot device without entering BIOS SETUP Utility.

PhoenixBIOS Setup Utility					
Information	Main	Advanced	Security	Boot	Exit
CPU Type :	Intel (R) Core-TM T7400@2.166GHz				
CPU Speed :	2.16GHz				
IDE1 Model Name :	TOSHIBA MK3018GAP-(PM)				
IDE1 Serial Number :	TSSTcorpCD/DVDW TS-L632D-MP2YH1XBGALJEE				
ATAPI Model Name:	Slimtype DVD-ROM LSD-.81-(SM)				
System BIOS Version:	V0.10				
VGA BIOS Version:					
KBC BIOS Version:					
Serial Number	xxxxxxxxxxxxxxxxxxxxxxxx				22 Byte
Asset Tag Number	N/A				32 Byte
Produce Name	TravelMate 3030/3040				16 Byte
Manufacturer Name:	Acer Inc.				16 Byte
UUID:	xxxxxxxxxxxxxxxxxxxxxxxxxxxxxxxx				32 Byte
F1 Help	↑↓ Select Item	F5/F6 Change Values	F9 Setup Defaults		
Esc Exit	←→ Select Menu	Enter Select	▶ Sub-Menu	F10 Save and Exit	

Navigating the BIOS Utility

There are six menu options: Info., Main, System Devices, Security, Boot, and Exit.

Follow these instructions:

- To choose a menu, use the cursor left/right keys (← →).
- To choose a parameter, use the cursor up/down keys (↑ ↓).
- To change the value of a parameter, press F5 or F6.
- A plus sign (+) indicates the item has sub-items. Press ENTER to expand this item.
- Press ESC while you are in any of the menu options to go to the Exit menu.
- In any menu, you can load default settings by pressing F8. You can also press F9 to save any changes made and exit the BIOS Setup Utility.

NOTE: You can change the value of a parameter if it is enclosed in square brackets. Navigation keys for a particular menu are shown on the bottom of the screen. Help for parameters are found in the Item Specific Help part of the screen. Read this carefully when making changes to parameter values. **Please note that system information is subject to different models.**

Information

PhoenixBIOS Setup Utility

Information
Main
Advanced
Security
Boot
Exit

```

CPU Type :           Intel (R) Core-TM T7400@2.166GHz
CPU Speed :          2.16GHz

IDE1 Model Name :    TOSHIBA MK3018GAP-(PM)
IDE1 Serial Number : TSSTcorpCD/DVDW TS-L632D-MP2YH1XBGALJEE
ATAPI Model Name:    Slimtype DVD-ROM LSD-.81-(SM)

System BIOS Version: V0.10
VGA BIOS Version:
KBC BIOS Version:

Serial Number        xxxxxxxxxxxxxxxxxxxxxxxxx          22 Byte
Asset Tag Number     N/A                                  32 Byte
Produce Name         TravelMate 3030/3040                 16 Byte
Manufacturer Name:   Acer Inc.                            16 Byte
UUID:                xxxxxxxxxxxxxxxxxxxxxxxxx          32 Byte
    
```

F1 Help	↑↓ Select Item	F5/F6 Change Values	F9 Setup Defaults
Esc Exit	←→ Select Menu	Enter Select	▶ Sub-Menu
			F10 Save and Exit

NOTE: The system information is subject to different models.

Parameter	Description
CPU Type	This field shows the CPU type and speed of the system.
IDE1 Model Name	This field shows the model name of HDD installed on primary IDE master.
IDE1 Serial Number	This field displays the serial number of HDD installed on primary IDE master.
IDE2I Model Name	This field displays the mofel name of devices installed on secondary IDE master. The hard disk drive or optical drive model name is automatically detected by the system.
IDE2 Serial Number	This field shows the serial number of devices installed on secondary IDE master.
System BIOS ver	Displays system BIOS version.
VGA BIOS Ver	This field displays the VGA firmware version of the system.
KBC Ver	This field shows the keyboard
Serial Number	This field displays the serial number of this unit.
Asset Tag Number	This field displays the asset tag number of the system.
Product Name	This field shows product name of the system.
Manufacturer Name	This field displays the manufacturer of this system.

Parameter	Description
UUID Number	This will be visible only when an internal LAN device is presenting. UUID=32bytes

Main

The Main screen displays a summary of your computer hardware information, and also includes basic setup parameters. It allows the user to specify standard IBM PC AT system parameters.

PhoenixBIOS Setup Utility					
Information	Main	Advanced	Security	Boot	Exit
					Item Specific Help
System Time:	[13:51:27]				<Tab>, <Shift-Tab>, or <Enter> selects field.
System Date:	[10/17/2006]				
System Memory:	640 KB	Shows system base memory size			
Extended Memory:	1022 MB	Shows extended memory size			
Video Memory:	128MB				
Quiet Boot:	[Enabled]				
Power on display:	[Auto]				
Network boot	[Enabled]				
F12 Boot Menu	[Disabled]				
D2D Recovery	[Enabled]				
F1 Help	↑↓ Select Item	F5/F6 Change Values	F9 Setup Defaults		
Esc Exit	←→ Select Menu	Enter Select	▶ Sub-Menu	F10 Save and Exit	

NOTE: The screen above is for your reference only. Actual values may differ.

The table below describes the parameters in this screen. Settings in **boldface** are the default and suggested parameter settings.

Parameter	Description	Format/Option
System Time	Sets the system time. The hours are displayed with 24-hour format.	Format: HH:MM:SS (hour:minute:second) System Time
System Date	Sets the system date.	Format MM/DD/YYYY (month/day/year) System Date
System Memory	This field reports the memory size of the system. Memory size is fixed to 640MB	
Extended Memory	This field reports the memory size of the extended memory in the system. Extended Memory size=Total memory size-1MB	
VGA Memory	Shows the VGA memory size. VGA Memory size=64/128MB	
Quiet Boot	Determines if Customer Logo will be displayed or not; shows Summary Screen is disabled or enabled. Enabled: Customer Logo is displayed, and Summary Screen is disabled. Disabled: Customer Logo is not displayed, and Summary Screen is enabled.	Option: Enabled or Disabled
Power on display	Auto: During power process, the system will detect if any display device is connected on external video port. If any external display device is connected, the power on display will be in CRT (or projector) only mode. Otherwise it will be in LCD only mode. Both: Simultaneously enable both the integrated LCD screen and the system's external video port (for an external CRT or projector).	Option: Auto or Both
Network Boot	Enables, disables the system boot from LAN (remote server).	Option: Enabled or Disabled
F12 Boot Menu	Enables, disables Boot Menu during POST.	Option: Disabled or Enabled
D2D Recovery	Enables, disables D2D Recovery function. The function allows the user to create a hidden partition on hard disc drive to store operation system and restore the system to factory defaults.	Option: Enabled or Disabled

NOTE: The sub-items under each device will not be shown if the device control is set to disable or auto. This is because the user is not allowed to control the settings in these cases.

Advanced

The Main screen displays a summary of your computer hardware information, and also includes basic setup parameters. It allows the user to specify standard IBM PC AT system parameters.

PhoenixBIOS Setup Utility					
Information	Main	Advanced	Security	Boot	Exit
Serial port :		[Auto]	Item Specific Help		
Parallel port :		[Enabled]	Configure serial port A using options: [Disabled] No configuration [Enabled] User configuration [Auto] BIOS or OS chooses configuration (OS Controlled) Displayed when controlled by OS		
Mode :		[ECP]			
Infrared Port (FIR) :		[Enabled]			
F1 Help	↑ ↓	Select Item	F5/F6	Change Values	F9 Setup Defaults
Esc Exit	← →	Select Menu	Enter	Select ▶ Sub-Menu	F10 Save and Exit

NOTE: The screen above is for your reference only. Actual values may differ.

The table below describes the parameters in this screen. Settings in **boldface** are the default and suggested parameter settings.

	Description	Option
Serial Port	Configure serial port A using options: [Disabled]: No configuration [Enabled]: User configuration [Auto]: BIOS or OS chooses configuration (OS Controlled) Displayedd when controlled by OS	Disabled Enabled Auto
Infrared Port	Configure serial port B using options: [Disabled]: No configuration [Enabled]: User configuration [Auto]: BIOS or OS chooses configuration (OS Controlled) Displayedd when controlled by OS	Disabled Enabled Auto
Parallel Port	Configure serial port B using options: [Disabled]: No configuration [Enabled]: User configuration [Auto]: BIOS or OS chooses configuration (OS Controlled) Displayedd when controlled by OS	Disabled Enabled Auto
Mode	Set the mode for the parallel port	Output only Bi-directional EPP ECP

NOTE: The sub-items under each device will not be shown if the device control is set to disable or auto. This is because the user is not allowed to control the settings in these cases.

Security

The Security screen contains parameters that help safeguard and protect your computer from unauthorized use.

PhoenixBIOS Setup Utility				
Information	Main	Security	Boot	Exit
Supervisor Password Is : Clear User Password Is : Clear HDD 0 Password Clear Set Supervisor Password [Enter] Set User Password [Enter] Set HDD 0 Password [Enter] Password on Boot [Disabled]				Item Specific Help Supervisor Password controls accesses of the whole setup utility. It can be used to boot up when Password on boot is enabled.
F1 Help	↑↓ Select Item	F5/F6 Change Values	F9 Setup Defaults	
Esc Exit	←→ Select Menu	Enter Select	▶ Sub-Menu	F10 Save and Exit

NOTE: Please refer to “Remove HDD/BIOS Password” section if you need to know how to remove HDD/BIOS Password.

The table below describes the parameters in this screen. Settings in **boldface** are the default and suggested parameter settings.

Parameter	Description	Option
User Password is	Shows the setting of the user password.	Clear or Set
Supervisor Password is	Shows the setting of the Supervisor password	Clear or Set
Set User Password	Press Enter to set the user password. When user password is set, this password protects the BIOS Setup Utility from unauthorized access. The user can enter Setup menu only and does not have right to change the value of parameters.	
Set Supervisor Password	Press Enter to set the supervisor password. When set, this password protects the BIOS Setup Utility from unauthorized access. The user can not either enter the Setup menu nor change the value of parameters.	
Primary HardDisk Security	Enables or disables primary hard disk security function.	
Password on Boot	Defines whether a password is required or not while the events defined in this group happened. The following sub-options are all requires the Supervisor password for changes and should be grayed out if the user password was used to enter setup.	Disabled or Enabled

NOTE: When you are prompted to enter a password, you have three tries before the system halts. Don't forget your password. If you forget your password, you may have to return your notebook computer to your dealer to reset it.

Setting a Password

Follow these steps as you set the user or the supervisor password:

1. Use the **↑** and **↓** keys to highlight the Set Supervisor Password parameter and press the **ENTER** key. The Set Supervisor Password box appears:

Set Supervisor Password

Enter New Password []

Confirm New Password []

2. Type a password in the "Enter New Password" field. The password length can not exceeds 8 alphanumeric characters (A-Z, a-z, 0-9, not case sensitive). Retype the password in the "Confirm New Password" field.

IMPORTANT: Be very careful when typing your password because the characters do not appear on the screen.

3. Press **ENTER**.
4. After setting the password, the computer sets the User Password parameter to "Set".
4. If desired, you can opt to enable the Password on boot parameter.
5. When you are done, press **F10** to save the changes and exit the BIOS Setup Utility.

Removing a Password

Follow these steps:

1. Use the **↑** and **↓** keys to highlight the Set Supervisor Password parameter and press the **ENTER** key. The Set Password box appears:

Set Supervisor Password

Enter current password []

Enter New Password []

Confirm New Password []

2. Type the current password in the Enter Current Password field and press **ENTER**.
3. Press **ENTER** twice **without** typing anything in the Enter New Password and Confirm New Password fields. The computer then sets the Supervisor Password parameter to “Clear”.
4. When you have changed the settings, press **F10** to save the changes and exit the BIOS Setup Utility.

Changing a Password

1. Use the **↑** and **↓** keys to highlight the Set Supervisor Password parameter and press the **ENTER** key. The Set Password box appears:

Set Supervisor Password

Enter current password []

Enter New Password []

Confirm New Password []

2. Type the current password in the Enter Current Password field and press **ENTER**.
3. Type a password in the Enter New Password field. Retype the password in the Confirm New Password field.
4. Press **ENTER**. After setting the password, the computer sets the User Password parameter to “Set”.
5. If desired, you can enable the Password on boot parameter.
6. When you are done, press **F10** to save the changes and exit the BIOS Setup Utility.

If the verification is OK, the screen will display as following.

Setup Notice

Changes have been saved.

[continue]

The password setting is complete after the user presses **F10**.

If the current password entered does not match the actual current password, the screen will show you the Setup Warning.



Setup Warning
Invalid password
Re-enter Password
[continue]

A rectangular dialog box with a black border containing four lines of centered text.

If the new password and confirm new password strings do not match, the screen will display the following message.

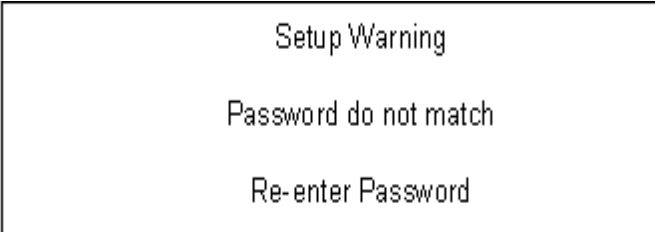

Setup Warning
Password do not match
Re-enter Password

A rectangular dialog box with a black border containing three lines of centered text.

Boot

This menu allows the user to decide the order of boot devices to load the operating system. Bootable devices includes the distette drive in module bay, the onboard hard disk drive and the CD-ROM in module bay.

PhoenixBIOS Setup Utility			
Information	Main	Security	Boot
<p>Boot priority order:</p> <p>1: IDE 0: WDC WD200EB -(PM)</p> <p>2: IDE 1: SAMSUNG CD-ROM</p> <p>3: 1394 CD-ROM:</p> <p>4: Network Boot:</p> <p>5: USB HDD:</p> <p>6: USB CD-ROM:</p> <p>7: USB Floppy:</p> <p>8: USB Key:</p> <p>Excluded from boot order:</p>		<p>Item Specific Help</p> <p>Keys used to view or configure device:</p> <p>Use Up and Down arrows to select a device.</p> <p><+> and <-> moves the device up or down.</p> <p><f> and <r> specifies the device fixed or removable.</p> <p><x> exclude or include the device to boot.</p> <p><Shift +1> enables or disables a device.</p> <p><1 - 4> Loads default boot sequence.</p>	
F1 Help	↑↓ Select Item	F5/F6 Change Values	F9 Setup Defaults
Esc Exit	←→ Select Menu	Enter Select ▶ Sub-Menu	F10 Save and Exit

Exit

The Exit screen contains parameters that help safeguard and protect your computer from unauthorized use.

The screenshot shows the PhoenixBIOS Setup Utility interface. At the top, the title is "PhoenixBIOS Setup Utility". Below it is a menu bar with options: Information, Main, Advanced, Security, Boot, and Exit. The main content area is divided into two sections. The left section lists several options: Exit Saving Changes, Exit Disarding Changes, Load Setup Defaults, Discard Changes, and Save Changes. The right section is titled "Item Specific Help" and contains the text: "Exit System Setup and save your changes to CMOS." At the bottom of the screen, there is a footer bar with keyboard shortcuts: F1 Help, Esc Exit, arrow keys for navigation, F5/F6 Change Values, Enter Select, F9 Setup Defaults, and F10 Save and Exit.

The table below describes the parameters in this screen.

Parameter	Description
Exit Saving Changes	Exit System Setup and save your changes to CMOS.
Exit Discarding Changes	Exit utility without saving setup data to CMOS.
Load Setup Default	Load default values for all SETUP item.
Discard Changes	Load previous values from CMOS for all SETUP items.
Save Changes	Save Setup Data to CMOS.

BIOS Flash Utility

The BIOS flash memory update is required for the following conditions:

- New versions of system programs
- New features or options
- Restore a BIOS when it becomes corrupted.

Use the Phlash utility to update the system BIOS flash ROM.

NOTE: If you do not have a crisis recovery diskette at hand, then you should create a **Crisis Recovery Diskette** before you use the Phlash utility.

NOTE: Do not install memory-related drivers (XMS, EMS, DPMS) when you use the Phlash.

NOTE: Please use the AC adaptor power supply when you run the Phlash utility. If the battery pack does not contain enough power to finish BIOS flash, you may not boot the system because the BIOS is not completely loaded.

Follow the steps below to run the Phlash.

1. Prepare a bootable diskette.
2. Copy the flash utilities to the bootable diskette.
3. Then boot the system from the bootable diskette. The flash utility has auto-execution function.

Remove HDD/BIOS Utility

This section provide you with removing HDD/BIOS method:

Remove HDD Password:

- ❑ If you key in wrong HDD password for three time, “HDD password error code” would display on the screen. See the image below.

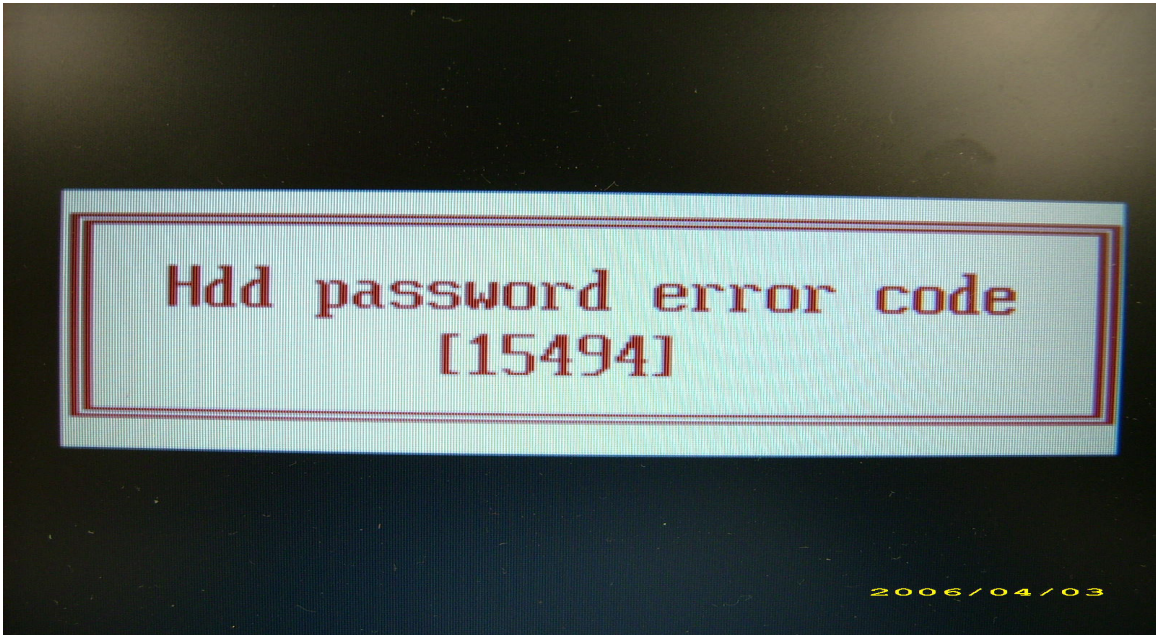

- ❑ If you need to solve HDD password locked problem, you can run HDD_PW.EXE
 1. Key in “hdd_pw 15494 0”
 2. Select “2”
 3. Choose one upper-case string

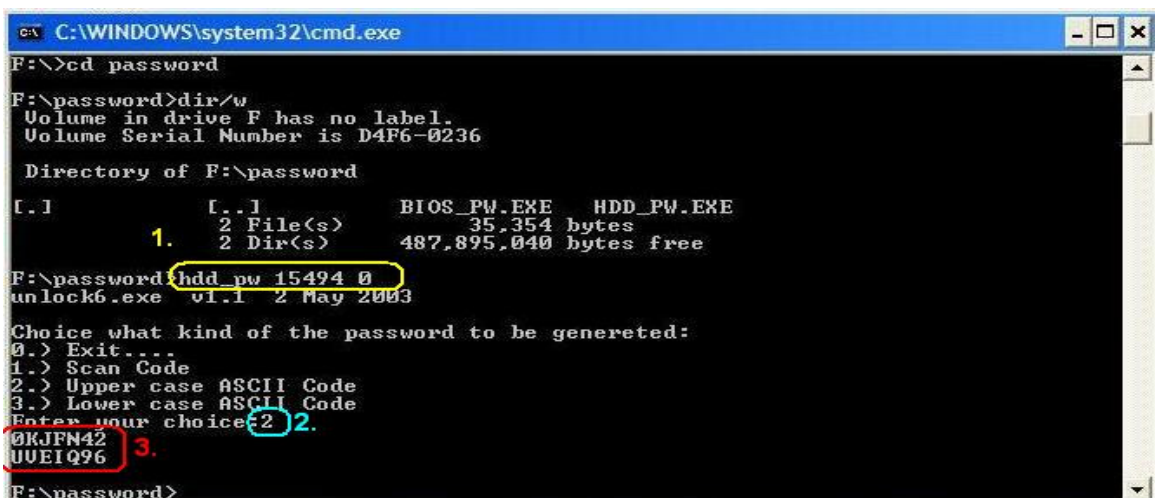

- ❑ Reboot system and key in “0KJFN42” or “UVEIQ96” to HDD user password.

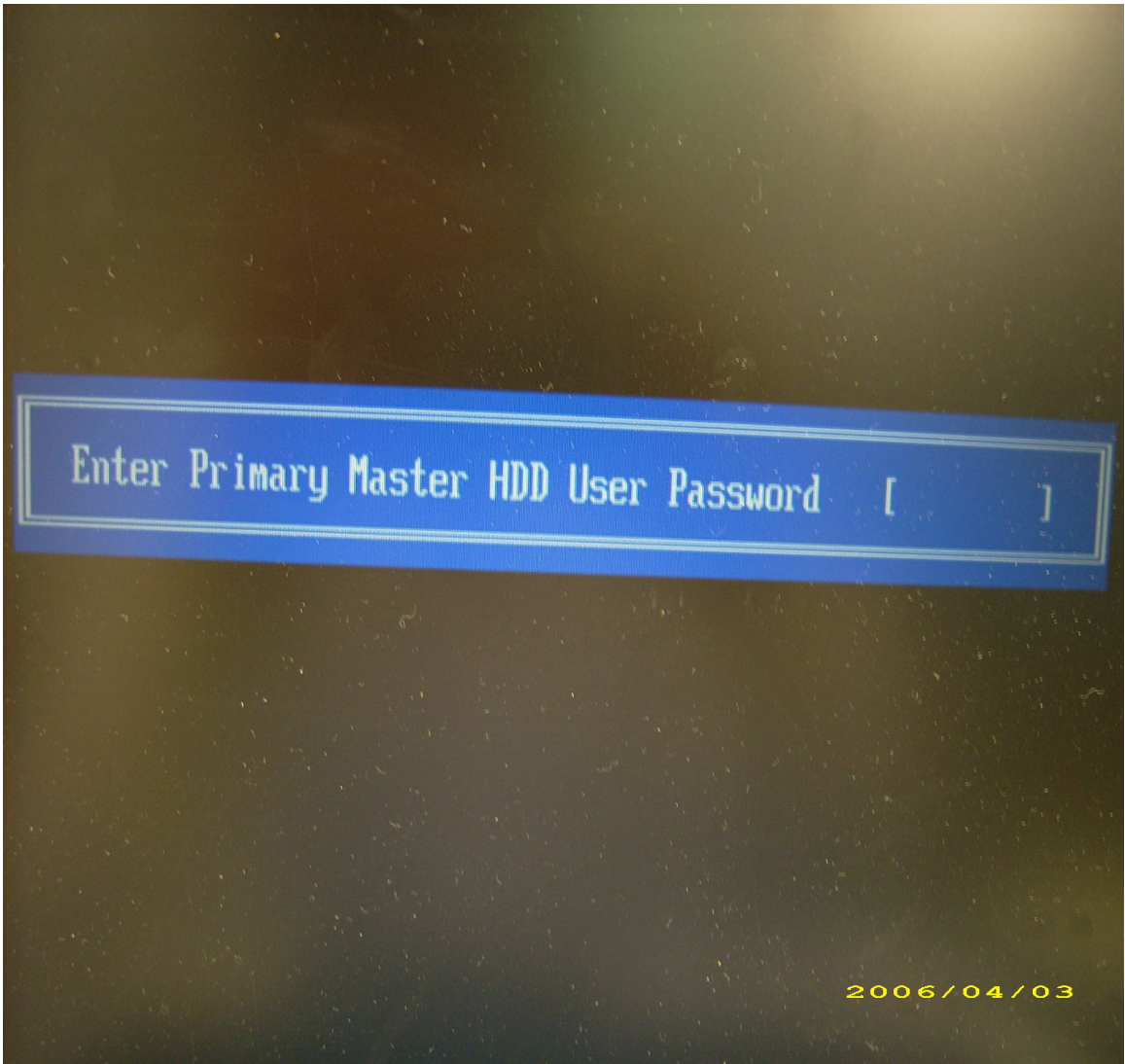

Remove BIOS Password:

- If you key in wrong Supervisor Password for three time, "System Disabled" would display on the screen. See the image below.

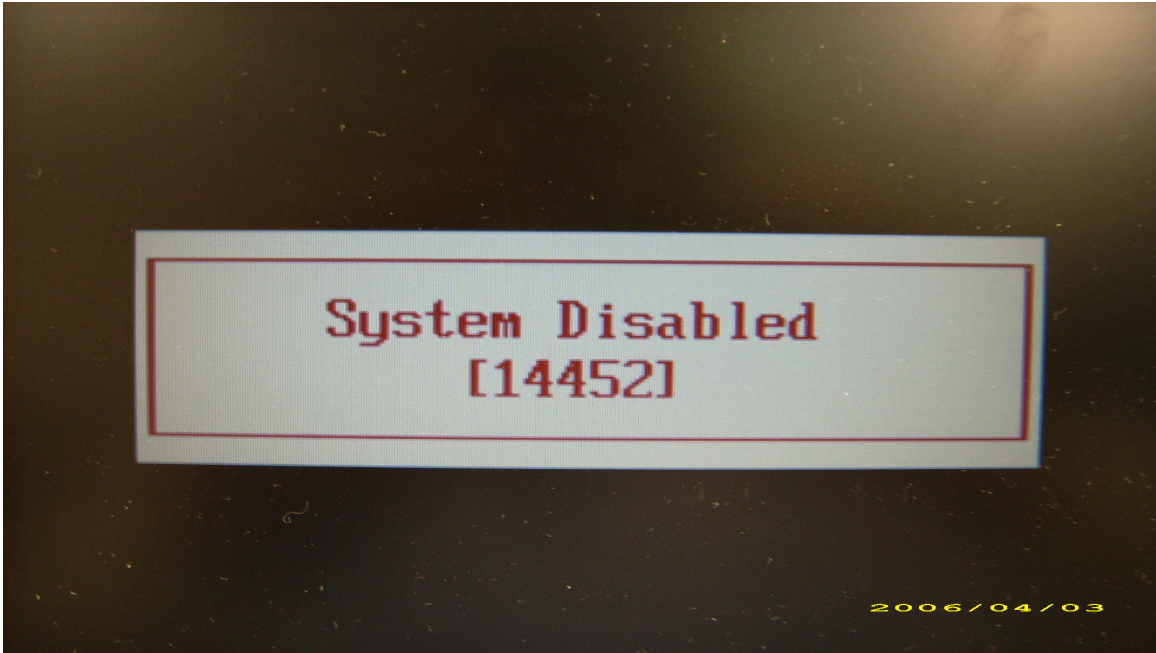

- ❑ If you need to solve BIOS password locked problem, you can run BIOS_PW.EXE
 1. Key in "bios_pw 14452 0"
 2. Choose one upper-case string

```
C:\WINDOWS\system32\cmd.exe
Microsoft Windows XP [Version 5.1.2600]
(C) Copyright 1985-2001 Microsoft Corp.
C:\Documents and Settings\M54>d:
D:\>bios_pw 14452 0
unlock6.exe v1.0 1 July 1997
qjjg9vy
07yqmjd
cjl14tm
6mbzjaj
D:\>_
```

- ❑ Reboot the system and key in "qjjg9vy" or "07yqmjd" to BIOS user password.



Machine Disassembly and Replacement

This chapter contains step-by-step procedures on how to disassemble the notebook computer for maintenance and troubleshooting.

To disassemble the computer, you need the following tools:

- Wrist grounding strap and conductive mat for preventing electrostatic discharge
- Small Philips screw driver
- Philips screwdriver
- Plastic flat head screw driver
- Tweezers

NOTE: The screws for the different components vary in size. During the disassembly process, group the screws with the corresponding components to avoid mismatch when putting back the components. When you remove the stripe cover, please be careful not to scrape the cover.

General Information

Before You Begin

Before proceeding with the disassembly procedure, make sure that you do the following:

1. Turn off the power to the system and all peripherals.
2. Unplug the AC adapter and all power and signal cables from the system.
3. Remove the battery pack.

NOTE: TravelMate 3000 series product uses mylar or tape to fasten the FFC/FPC/connectors/cable, you may need to tear the tape or mylar before you disconnect different FFC/FPC/connectors.

NOTE: There are several types of screws used to secure bottom case and upper case assembly. The screws vary in length. Please refer the picture below, group the same type of screws together during service disassembling. Please also remember the screw location for each screw type. If you fasten the screw to the wrong location, the screw may be too long to damage the main board.

Disassembly Procedure Flowchart

The flowchart on the succeeding page gives you a graphic representation on the entire disassembly sequence and instructs you on the components that need to be removed during servicing. For example, if you want to remove the main board, you must first remove the keyboard, then disassemble the inside assembly frame in that order.

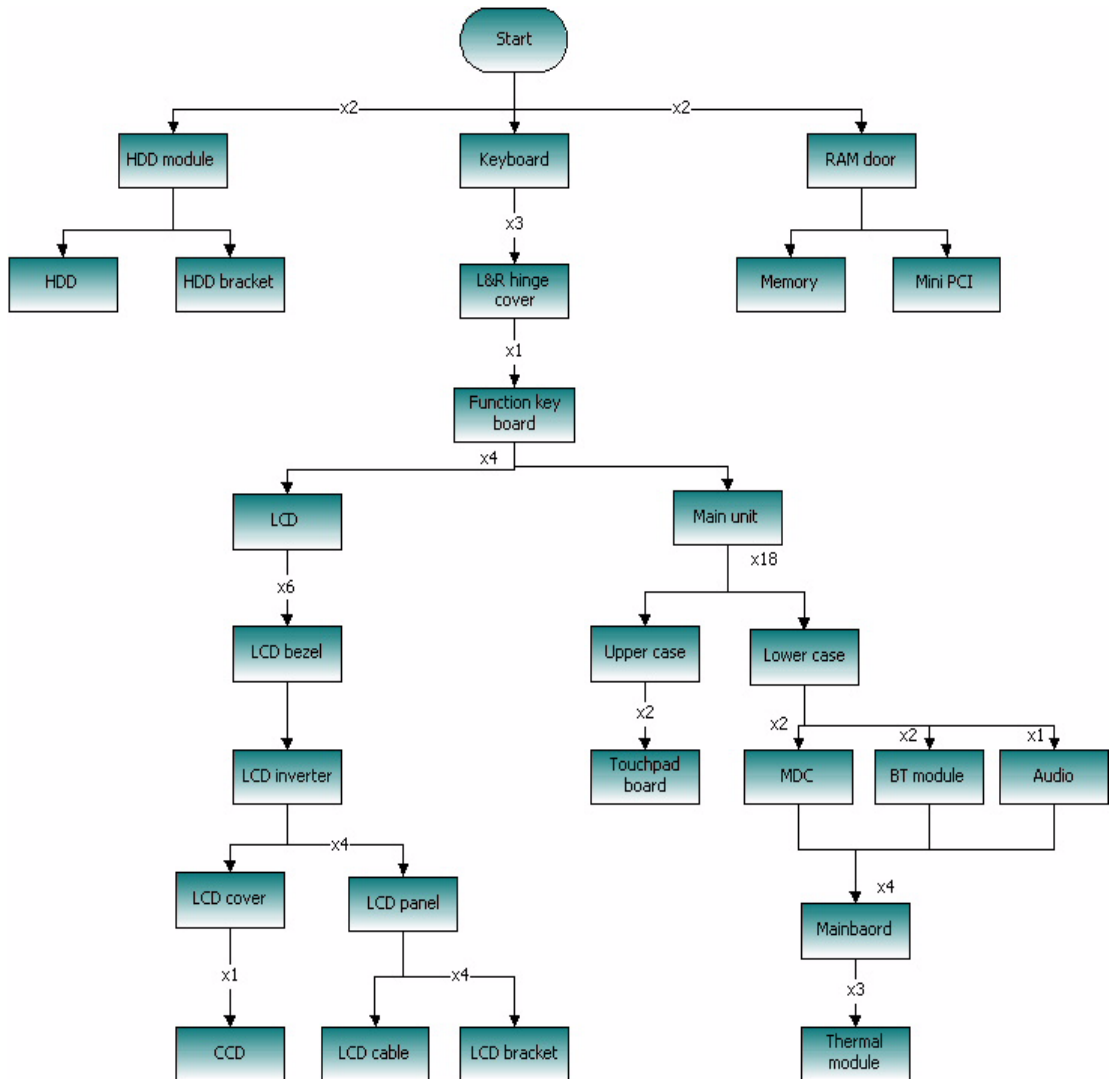

Removing the Battery Pack

1. Release the battery lock.
2. Slide the battery latch.
3. Remove the battery pack.

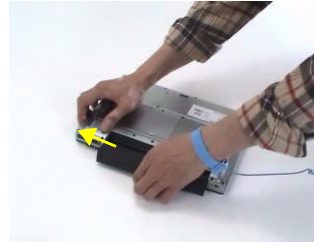

Removing the miniPCI/Memory/HDD Module/Keyboard

Removing the miniPCI and Memory

1. Remove the two screws that secure the RAM door and remove the RAM door.
2. Release the wireless antenna.
3. Remove the two screws securing the miniPCI card.
4. Press the latch on left and right side to pop out the miniPCI and remove it.
5. Press the latch on left and right side to pop out the memory and remove it.
6. Press the latch on left and right side to pop out the other memory and remove it.

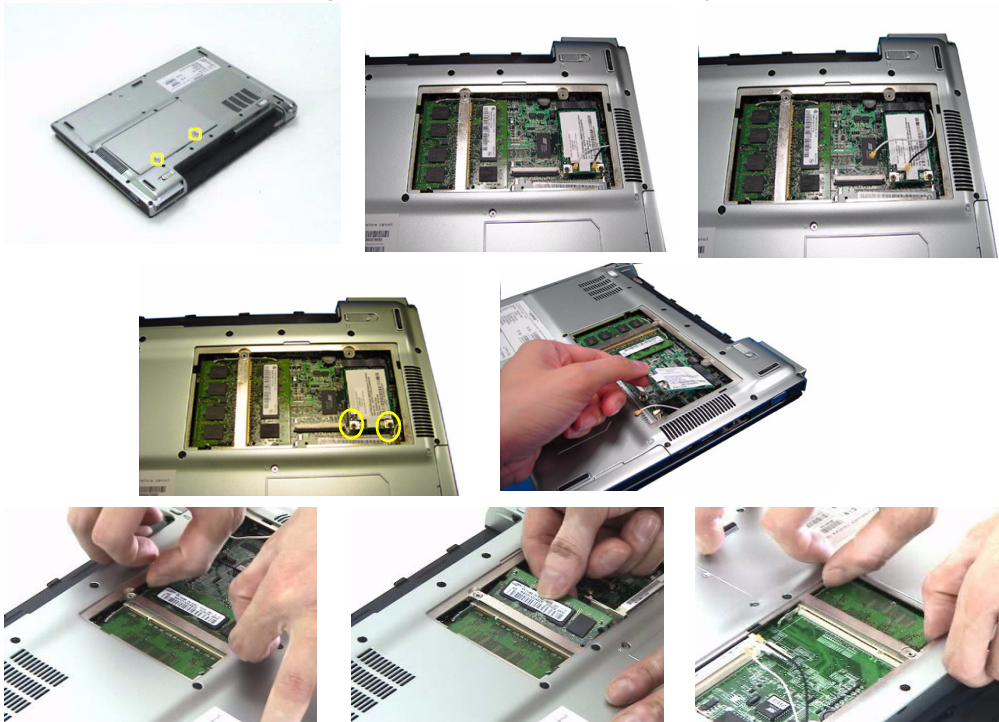

Removing the HDD

1. Remove the two screws that secure the HDD.
2. Pull the HDD out and remove it from the main unit.



Removing the keyboard

1. Open the LCD panel.

2. Press the two inner keyboard latches that secure the keyboard with flat screw driver.
3. Release another two outer keyboard latches.
4. Pull the keyboard and turn it over.
5. Disconnect the keyboard FFC from the mainboard.
6. Remove the keyboard from the main unit.

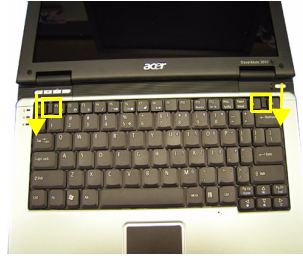
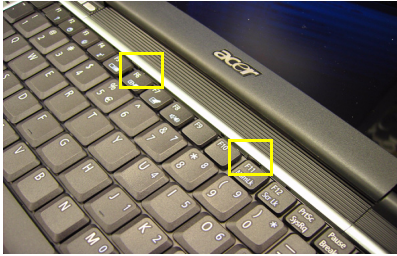

Separate the LCD module and main unit

1. Disconnect the function key board FFC from the mainboard.
2. Disconnect the LCD cable from the mainboard.
3. Disconnect the touchpad board FFC from the mainboard.

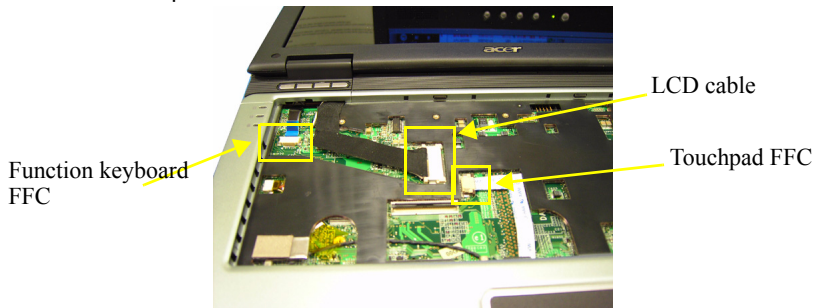

4. Remove the three screws that secure the left and right hinge cover.
5. Pull the left hinge up and slide it out as show.
6. Pull the right hinge cover up and slide it out as show.
7. Disconnect the function key board FFC from the function key board.
8. Remove the screw that secures the function key board.
9. Remove the function key board from the left hinge cover.
10. Pull the wireless antenna out.
11. Remove the two screws securing the left and right hinges.
12. Detach the LCD module from the main unit.

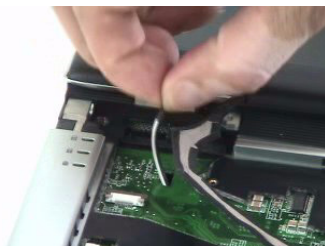

Disassemble the main unit

Separate upper and lower case

1. Turn the main unit over.
2. Remove the eighteen screws that secure the lower case.
3. Detach the upper case from the lower case assembly.

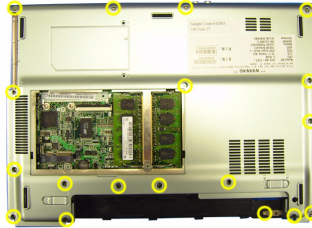

Removing the Bluetooth module

1. Tear off the mylar on the Bluetooth cable
2. Disconnect the Bluetooth cable from the mainboard.
3. Remove the two screws that secure the Bluetooth module.
4. Remove the Bluetooth module from the mainboard.
5. Disconnect the Bluetooth cable from the Bluetooth module.

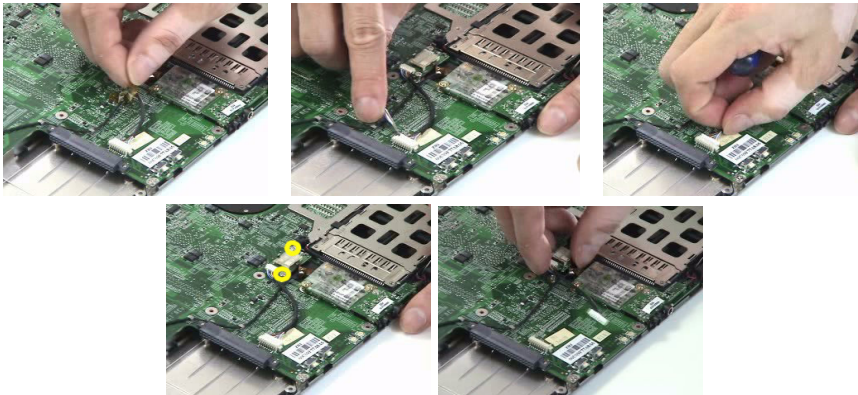

Removing the MDC module

1. Tear off the mylar on the MDC cable.
2. Disconnect the MDC cable from the mainboard.
3. Remove the MDC cable from the wire groove.
4. Remove the two screws that secure the MDC board.
5. Remove the MDC board from the mainboard.

- Disconnect the MDC cable from the MDC board.

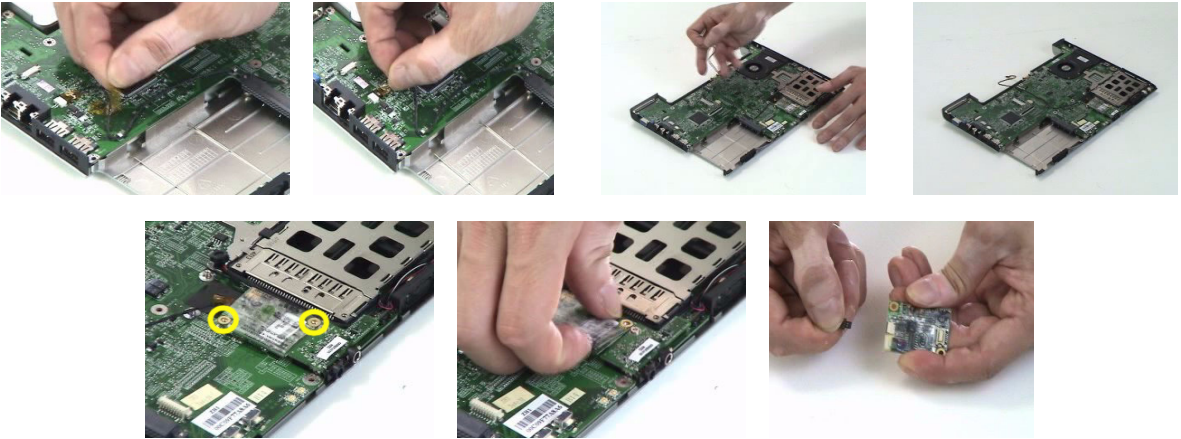

Removing the audio module

- Remove the screw that secures the audio board.
- Remove the audio board from the mainboard.

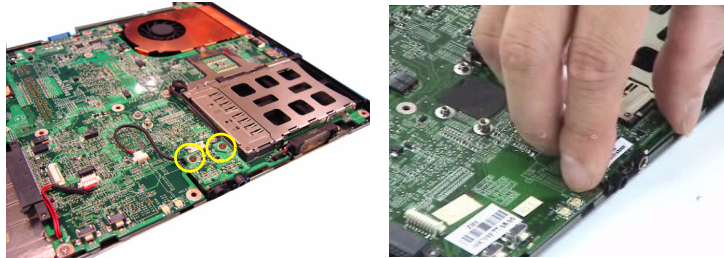

Removing the mainboard from lower case

- Press the button and remove the dummy card from the PCMCIA card slot.

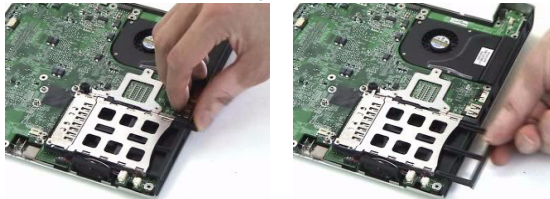

- Disconnect the speaker cable from the mainboard.
- Disconnect the microphone cable from the mainboard.

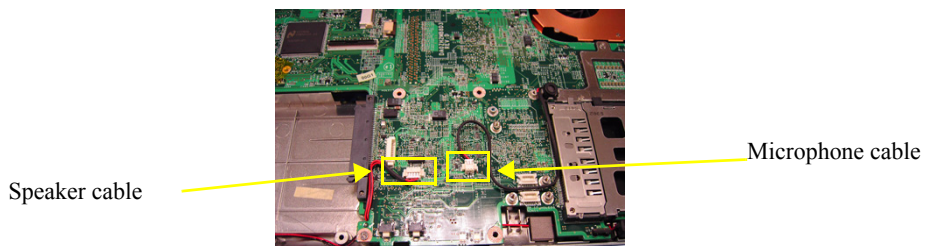

- Remove the four screws that secure the mainboard.
- Detach the mainboard from the lower case.
- Disconnect the power board cable from the mainboard and remove the power board from the mainboard.

7. Remove the three screws that secure the thermal following the order 1, 2, 3.
8. Disconnect the fan cable from the mainboard.
9. Remove the thermal module from the mainboard.

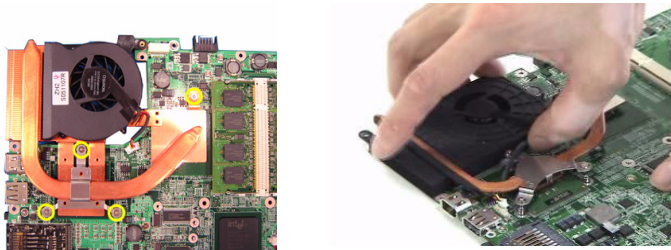

10. Tear off the mylar on the touchpad board FFC.
11. Disconnect the touchpad board FFC from the touchpad board.
12. Disconnect another FFC from the touchpad board.
13. Remove the two screws that secure the touchpad board.
14. Remove the touchpad board from the upper case.
15. This completes the main unit disassembly.

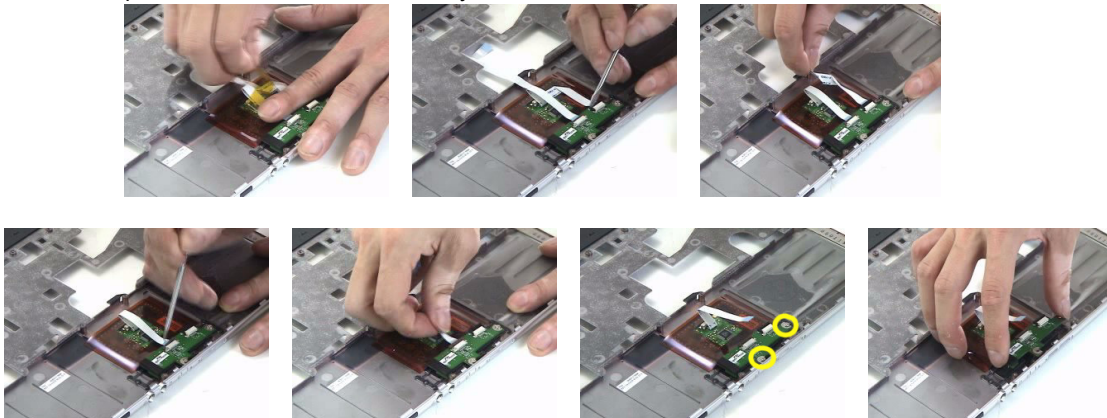

LCD module disassembly

1. Remove the six screw pads.
2. Remove the six screws that secure the LCD bezel.



3. Release the latches one by one. **Please note that the bezel is fragile. Need to follow the following disassembly pictures from left to right.**



4. Pull the bezel a little bit forward that paralleled LCD cover and remove the LCD bezel.



5. Pull the inverter board out.
6. Disconnect the LVDS cable from the inverter board.
7. Disconnect the LCD cable from the inverter board.
8. Remove the inverter board.



9. Remove the four screws that secure the LCD and disconnect the CCD cable.
10. Remove the LCD from the cover assembly.
11. Remove the screw securing the CCD.
12. Remove the CCD from the cover assembly.

13. Remove the wireless antenna from the cover assembly.

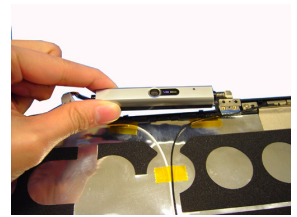
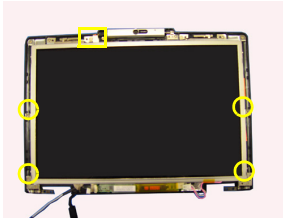

14. Remove the two screws that secure the left LCD bracket.

15. Remove the left LCD bracket from the LCD.

16. Remove the two screws that secure the right LCD bracket.

17. Remove the right LCD bracket from the LCD.

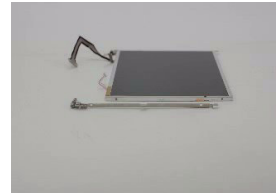
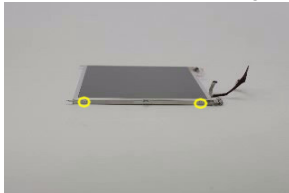

18. Turn the LCD back.

19. Tear off the tape on the LCD cable.

20. Disconnect the LCD cable from the LCD.

21. This completes the LCD disassembly.

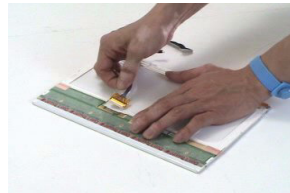

HDD Disassembly and Reassembly

1. Remove the two screws that secure the HDD holder on one side.
2. Remove the two screws that secure the HDD holder on the other side.
3. Lift up the HDD and remove it from the HDD holder.
4. Place the HDD back to the HDD holder
5. Secure the HDD with two screws on one side.
6. This complete the HDD module disassembly and reassembly.



Troubleshooting

Use the following procedure as a guide for computer problems.

NOTE: The diagnostic tests are intended to test this model. Non-Acer products, prototype cards, or modified options can give false errors and invalid system responses.

1. Duplicate symptom and obtain the failing symptoms in as much detail as possible.
2. Distinguish symptom. Verify the symptoms by attempting to re-create the failure by running the diagnostic test or by repeating the same operation.
3. Disassemble and assemble the unit without any power sources.
4. If any problem occurs, you can perform visual inspection before you follow this chapter's instructions. You can check the following:
 - power cords are properly connected and secured;
 - there are no obvious shorts or opens;
 - there are no obviously burned or heated components;
 - all components appear normal.
5. Use the following table with the verified symptom to determine which page to go to.

Symptoms (Verified)	Go To
Power failure. (The power indicator does not go on or stay on.)	"Power System Check" on page 77.
POST does not complete. No beep or error codes are indicated.	"Power-On Self-Test (POST) Error Message" on page 79 "Undetermined Problems" on page 91
POST detects an error and displayed messages on screen.	"Error Message List" on page 80
Other symptoms (i.e. LCD display problems or others).	"Power-On Self-Test (POST) Error Message" on page 79
Symptoms cannot be re-created (intermittent problems).	Use the customer-reported symptoms and go to "Power-On Self-Test (POST) Error Message" on page 79 "Intermittent Problems" on page 90 "Undetermined Problems" on page 91

System Check Procedures

External Diskette Drive Check

If an error occurs with the internal diskette drive, reconnect the diskette connector on the system board.

If the error still remains:

1. Reconnect the external diskette drive/DVD-ROM module.
2. Replace the external diskette drive/CD-ROM module.
3. Replace the main board.

External CD-ROM Drive Check

Do the following to isolate the problem to a controller, drive, or CD-ROM. Make sure that the CD-ROM does not have any label attached to it. The label can cause damage to the drive or can cause the drive to fail.

Do the following to select the test device:

1. Boot from the diagnostics diskette and start the diagnostics program.
2. See if CD-ROM Test is passed when the program runs to CD-ROM Test.
3. Follow the instructions in the message window.

If an error occurs, reconnect the connector on the System board. If the error still remains:

1. Reconnect the external diskette drive/CD-ROM module.
2. Replace the external diskette drive/CD-ROM module.
3. Replace the main board.

Keyboard or Auxiliary Input Device Check

Remove the external keyboard if the internal keyboard is to be tested.

If the internal keyboard does not work or an unexpected character appears, make sure that the flexible cable extending from the keyboard is correctly seated in the connector on the system board.

If the keyboard cable connection is correct, run the Keyboard Test.

If the tests detect a keyboard problem, do the following one at a time to correct the problem. Do not replace a non-defective FRU:

1. Reconnect the keyboard cables.
2. Replace the keyboard.
3. Replace the main board.

The following auxiliary input devices are supported by this computer:

- Numeric keypad
- External keyboard

If any of these devices do not work, reconnect the cable connector and repeat the failing operation.

Memory check

Memory errors might stop system operations, show error messages on the screen, or hang the system.

1. Boot from the diagnostics diskette and start the doagmpstotics program (please refer to main board).
2. Go to the diagnostic memory in the test items.
3. Press F2 in the test items.

-
4. Follow the instructions in the message window.

NOTE: Make sure that the DIMM is fully installed into the connector. A loose connection can cause an error.

Power System Check

To verify the symptom of the problem, power on the computer using each of the following power sources:

1. Remove the battery pack.
2. Connect the power adapter and check that power is supplied.
3. Disconnect the power adapter and install the charged battery pack; then check that power is supplied by the battery pack.

If you suspect a power problem, see the appropriate power supply check in the following list:

- “Check the Battery Pack” on page 78

Check the Battery Pack

To check the battery pack, do the following:

From Software:

1. Check out the Power Management in control Panel
2. In Power Meter, confirm that if the parameters shown in the screen for Current Power Source and Total Battery Power Remaining are correct.
3. Repeat the steps 1 and 2, for both battery and adapter.
4. This helps you identify first the problem is on recharging or discharging.

From Hardware:

1. Power off the computer.
2. Remove the battery pack and measure the voltage between battery terminals 1(+) and 6(ground). See the following figure
3. If the voltage is still less than 7.5 Vdc after recharging, replace the battery.

To check the battery charge operation, use a discharged battery pack or a battery pack that has less than 50% of the total power remaining when installed in the computer.

If the battery status indicator does not light up, remove the battery pack and let it return to room temperature. Re-install the battery pack.

If the charge indicator still does not light up, replace the battery pack. If the charge indicator still does not light up, replace the DC/DC charger board.

Touchpad check

If the touchpad doesn't work, do the following actions one at a time to correct the problem. Do not replace a non-defective FRU:

1. After rebooting, run Tracking Pad PS2 Mode Driver. For example, run Syn touch driver.
2. Run utility with the PS/2 mouse function and check if the mouse is working.
3. If the PS/2 mouse does not work, then check if the main board to switch board FPC is connected O.K.
4. If the main board to switch board FPC is connected well, then check if the FCC on touch pad PCB connects properly.
5. If the FFC on touch pad PCB connects properly, then check if LS851 JP1 Pin6=5V are pulse. If yes, then replace switch board. If no, then go to next step.
6. Replace touch pad PCB.
7. If the touch pad still does not work, then replace FPC on Track Pad PCB.

After you use the touchpad, the pointer drifts on the screen for a short time. This self-acting pointer movement can occur when a slight, steady pressure is applied to the touchpad pointer. This symptom is not a hardware problem. No service actions are necessary if the pointer movement stops in a short period of time.

Power-On Self-Test (POST) Error Message

The POST error message index lists the error message and their possible causes. The most likely cause is listed first.

NOTE: Perform the FRU replacement or actions in the sequence shown in FRU/Action column, if the FRU replacement does not solve the problem, put the original part back in the computer. Do not replace a non-defective FRU.

This index can also help you determine the next possible FRU to be replaced when servicing a computer.

If the symptom is not listed, see “Undetermined Problems” on page 91.

The following lists the error messages that the BIOS displays on the screen and the error symptoms classified by function.

NOTE: Most of the error messages occur during POST. Some of them display information about a hardware device, e.g., the amount of memory installed. Others may indicate a problem with a device, such as the way it has been configured.

NOTE: If the system fails after you make changes in the BIOS Setup Utility menus, reset the computer, enter Setup and install Setup defaults or correct the error.

Index of Error Messages

Error Message List

Error Messages	FRU/Action in Sequence
Struck Key	See "Keyboard or Auxiliary Input Device Check" on page 76
System CMOS checksum bad - Default configuration used	RTC battery Run BIOS Setup Utility to reconfigure system, then reboot system.
Real time clock error	RTC battery Run BIOS Setup Utility to reconfigure system time, then reboot system. Main board
Previous boot incomplete - Default configuration used	"Load Default Settings" in BIOS Setup Utility. RTC battery Main board
Invalid System Configuration Data	"Load Default Settings" in BIOS Setup Utility. Main board
Operating system not found	Enter Setup and see if fixed disk and drive A are properly identified. Diskette drive Hard disk drive Main board

Error Message List

No beep Error Messages	FRU/Action in Sequence
Power-on indicator turns off and LCD is blank.	Power source (battery pack and power adapter.) See "Power System Check" on page 77 Ensure every connector is connected tightly and correctly. Reconnect the DIMM. Main board.
Power-on indicator turns on and LCD is blank.	Power source (battery pack and power adapter.) See "Power System Check" on page 77 Reconnect the LCD connector Hard disk drive LCD cable LCD inverter LCD Main board
Power-on indicator turns on and LCD is blank. But you can see POST on an external CRT.	Reconnect the LCD connectors. LCD cable LCD inverter LCD Main board
Power-on indicator turns on and a blinking cursor shown on LCD during POST.	Ensure every connector is connected tightly and correctly. Main board

Phoenix BIOS Beep Codes

Code	Beeps	POST Routine Description
02h		Verify Real Mode
03h		Disable Non-Maskable Interrupt (NMI)
04h		Get CPU type
06h		Initialize system hardware
07h		Disable shadow and execute code from the ROM.
08h		Initialize chipset with initial POST values
09h		Set IN POST flag
0Ah		Initialize CPU registers
0Bh		Enable CPU cache
0Ch		Initialize caches to initial POST values
0Eh		Initialize I/O component
0Fh		Initialize the local bus IDE
10h		Initialize Power Management
11h		Load alternate registers with initial POST values
12h		Restore CPU control word during warm boot
13h		Initialize PCI Bus Mastering devices
14h		Initialize keyboard controller
16h	1-2-2-3	BIOS ROM checksum
17h		Initialize cache before memory autosize
18h		8254 timer initialization
1Ah		8237 DMA controller initialization
1Ch		Reset Programmable Interrupt Controller
20h	1-3-1-1	Test DRAM refresh
22h	1-3-1-3	Test 8742 Keyboard Controller
24h		Set ES segment register to 4 GB
28h		Autosize DRAM
29h		Initialize POST Memory Manager
2Ah		Clear 215 KB base RAM
2Ch	1-3-4-1	RAM failure on address line xxxx
2Eh	1-3-4-3	RAM failure on data bits xxxx of low byte of memory bus
2Fh		Enable cache before system BIOS shadow
32h		Test CPU bus-clock frequency
33h		Initialize Phoenix Dispatch Manager
36h		Warm start shut down
38h		Shadow system BIOS ROM
3Ah		Autosize cache
3Ch		Advanced configuration of chipset registers
3Dh		Load alternate registers with CMOS values
41h		Initialize extended memory for RomPilot.
42h		Initialize interrupt vectors
45h		POST device initialization

Code	Beeps	POST Routine Description
46h	2-1-2-3	Check ROM copyright notice
47h		Initialize I20 support
48h		Check video configuration against CMOS
49h		Initialize PCI bus and devices
4Ah		Initialize all video adapters in system
4Bh		QuietBoot start (optional)
4Ch		Shadow video BIOS ROM
4Eh		Display BIOS copyright notice
50h		Display CPU type and speed
51h		Initialize EISA board
52h		Test keyboard
54h		Set key click if enabled
55h		Enable USB devices
58h	2-2-3-1	Test for unexpected interrupts
59h		Initialize POST display service
5Ah		Display prompt "Press F2 to enter SETUP"
5Bh		Disable CPU cache
5Ch		Test RAM between 512 and 640 KB
60h		Test extended memory
62h		Test extended memory address lines
64h		Jump to User Patch1
66h		Configure advanced cache registers
67h		Initialize Multi Processor APIC
68h		Enable external and CPU caches
69h		Setup System Management Mode (SMM) area
6Ah		Display external L2 cache size
6Bh		Load custom defaults (optional)
6Ch		Display shadow-area message
6Eh		Display possible high address for UMB recovery
70h		Display error messages
72h		Check for configuration errors
76h		Check for keyboard errors
7Ch		Set up hardware interrupt vectors
7Eh		Initialize coprocessor if present
80h		Disable onboard Super I/O ports and IRQs
81h		Late POST device initialization
82h		Detect and install external RS232 ports
83h		Configure non-MCD IDE controllers
84h		Detect and install external parallel ports
85h		Initialize PC-compatible PnP ISA devices
86h		Re-initialize onboard I/O ports
87h		Configure Motherboard Configurable Devices (optional)
88h		Initialize BIOS Data Area
89h		Enable Non-Maskable Interrupts (NMI)

Code	Beeps	POST Routine Description
8Ah		Initialize Extended BIOS Data Area
8Bh		Test and initialize PS/2 mouse
8Ch		Initialize floppy controller
8Fh		Determine number of ATA drives (optional)
90h		Initialize hard-disk controllers
91h		Initialize local-bus hard-disk controllers
92h		Jump to UserPatch2
93h		Build MPTABLE for multi-processor boards
95h		Install CD ROM for boot
96h		Clear huge ES segment register
97h		Fixup Multi Processor table
98h	1-2	Search for option ROMs. One long, two short beeps on checksum failure.
99h		Check for SMART drive (optional)
9Ah		Shadow option ROMs
9Ch		Set up Power Management
9Dh		Initialize security engine (optional)
9Eh		Enable hardware interrupts
9Fh		Determine number of ATA and SCSI drives
A0h		Set time of day
A2h		Check key lock
A4h		Initialize Typematic rate
A8h		Erase F2 prompt
AAh		Scan for F2 key stroke
ACh		Enter SETUP
A Eh		Clear Boot flag
B0h		Check for errors
B1h		Inform RomPilot about the end of POST.
B2h		POST done- prepare to boot operating system
B4h	1	One short beep before boot
B5h		Terminate QuietBoot (optional)
B6h		Check password (optional)
B7h		Initialize ACPI BIOS
B9h		Prepare Boot
BAh		Initialize SMBIOS
BBh		Initialize PnP Option ROMs
BCh		Clear parity checkers
BDh		Display MultiBoot menu
BEh		Clear screen (optional)
BFh		Check virus and backup reminders
C0h		Try to boot with INT 19
C1h		Initialize POST Error Manager (PEM)
C2h		Initialize error logging
C3h		Initialize error display function
C4h		Initialize system error handler
C5h		PnPnd dual CMOS (optional)

Code	Beeps	POST Routine Description
C6h		Initialize notebook docking (optional)
C7h		Initialize notebook docking late
C8h		Force check (optional)
C9h		Extended checksum (optional)
CAh		Redirect Int 15h to enable remote keyboard
CBh		Redirect Int 13h to Memory Technologies Devices such as ROM, RAM, PCMCIA, and serial disk.
CCh		Redirect Int 10h to enable remote serial video
CDh		Re-map I/O and memory for PCMCIA
CEh		Initialize digitizer and display message.
D2h		Unknown interrupt
The following are for boot block in Flash ROM		
E0h		Initialize the chipset
E1h		Initialize the bridge
E2h		Initialize the CPU
E3h		Initialize the system timer
E4h		Initialize system I/O
E5h		Check force recovery boot
E6h		Checksum BIOS ROM
E7h		Go to BIOS
E8h		Set Huge Segment
E9h		Initialize Multi Processor
EAh		Initialize OEM special code
EBh		Initialize PIC and DMA
ECh		Initialize Memory type
EDh		Initialize Memory size
EEh		Shadow Boot Block
EFh		System memory test
F0h		Initialize interrupt vectors
F1h		Initialize Run Time Clock
F2h		Initialize video
F3h		Initialize System Management Mode
F4h	1	Output one beep
F5h		Clear Huge Segment
F6h		Boot to Mini DOS
F7h		Boot to Full DOS

Index of Symptom-to-FRU Error Message

LCD-Related Symptoms

Symptom / Error	Action in Sequence
LCD backlight doesn't work	First, plug a monitor to CRT port. Next, enter BIOS utility to running "Load Default Settings" then reboot the system. Reconnect the LCD connectors. Keyboard (if the brightness function key doesn't work). LCD cable LCD inverter LCD Main board
LCD is too dark LCD brightness cannot be adjusted	Enter BIOS Utility to execute "Load Setup Default Settings", then reboot system. Reconnect the LCD connectors. Keyboard (if the brightness function key doesn't work). LCD cable LCD inverter LCD Main board
Unreadable LCD screen Missing pels in characters Abnormal screen Wrong color displayed LCD has extra horizontal or vertical lines displayed.	Reconnect the LCD cable LCD cable LCD Main board

Indicator-Related Symptoms

Symptom / Error	Action in Sequence
Indicator incorrectly remains off or on, but system runs correctly	Main board
HDD/CD-ROM active indicators cannot work	HDD/CD-ROM drive Device driver Main board

Power-Related Symptoms

Symptom / Error	Action in Sequence
Power shuts down during operation	Power source (battery pack and power adapter). See "Power System Check" on page 77. Battery pack AC adapter See if the thermal module is overheat (Heat sink or fan). Main board
The system cannot power-on.	Power source (battery pack and power adapter). See "Power System Check" on page 77. Battery pack Power adapter CPU Main board
The system cannot power-off.	In Windows XP operating system, hold and press the power switch for more than 4 seconds. If the system can power off, then the main board is OK. Verify OS in the HDD. Main board

Power-Related Symptoms

Symptom / Error	Action in Sequence
Battery can't be charged or discharged	See "Check the Battery Pack" on page 78. Battery pack Main board
System hang during POST	ODD/HDD/FDD/RAM module Main board

PCMCIA-Related Symptoms

Symptom / Error	Action in Sequence
System cannot detect the PC Card (PCMCIA)	PCMCIA slot assembly Main board
PCMCIA slot pin is damaged.	PCMCIA slot assembly
PC Card cannot be inserted or ejected	Check if the PCMCIA slot is blocked Main board

Memory-Related Symptoms

Symptom / Error	Action in Sequence
Memory count (size) appears different from actual size.	Enter BIOS Setup Utility to execute "Load Default Settings" then reboot system. RAM module Main board Check BIOS revision
System can power on, but you hear two long beeps: "B--, B--" and the LCD is blank.	Reinsert DIMM DIMM Main board

Speaker-Related Symptoms

Symptom / Error	Action in Sequence
In Windows, multimedia programs, no sound comes from the computer.	OS volume control Audio driver Speaker Main board
Internal speakers make noise or emit no sound.	Speaker Main board
Microphone cannot work	Audio driver Volume control in Windows XP Main board

Power Management-Related Symptoms

Symptom / Error	Action in Sequence
The system will not enter hibernation mode	Power option in Windows XP Hard disk drive Main board
The system doesn't enter standby mode after closing the lid of the portable computer.	Driver of Power Option Properties Lid close switch in upper case Main board

Power Management-Related Symptoms

Symptom / Error	Action in Sequence
The system doesn't resume from hibernation/standby mode.	Connect AC adapter then check if the system resumes from Standby/Hibernation mode. Check if the battery is low. Hard disk drive Main board
The system doesn't resume from standby mode after opening the lid of the portable computer.	LCD cover switch Main board
Battery fuel gauge in Windows doesn't go higher than 90%.	Refresh battery (continue use battery until power off, then charge battery). Battery pack Main board
System hangs intermittently.	Reconnect hard disk/CD-ROM drives. Main board

Peripheral-Related Symptoms

Symptom / Error	Action in Sequence
System configuration does not match the installed devices.	Enter BIOS Setup Utility to execute "Load Setup defaults", then reboot system. Reconnect hard disk/CD-ROM drives/FDD or other peripherals. Main board
External display does not work correctly.	Press Fn+F5, LCD/CRT/Both display switching Keyboard Main board
USB does not work correctly	Main board
Print problems.	Enter BIOS Setup Utility to execute "Load Default Settings" then reboot the system. Run printer self-test. Printer driver Printer cable Printer Main board
Parallel port device problems	Enter BIOS Setup Utility to execute "Load Default Settings" then reboot the system. Device driver Device cable Device Main board

Keyboard/Touchpad-Related Symptoms

Symptom / Error	Action in Sequence
Keyboard (one or more keys) does not work.	Reconnect the keyboard cable. Keyboard Main board
Touchpad does not work.	Reconnect touchpad cable. Touchpad board Main board

Modem/LAN-Related Symptoms

Symptom / Error	Action in Sequence
Internal modem does not work correctly.	Phone cable Driver Reconnect the Internal modem cable to the main board tightly. Main board
Internal LAN does not work correctly	Lan cable Driver Main board

NOTE: If you cannot find a symptom or an error in this list and the problem remains, see “Undetermined Problems” on page 91.

Intermittent Problems

Intermittent system hang problems can be caused by a variety of reasons that have nothing to do with a hardware defect, such as: cosmic radiation, electrostatic discharge, or software errors. FRU replacement should be considered only when a recurring problem exists.

When analyzing an intermittent problem, do the following:

1. Run the diagnostic test for the system board in loop mode at least 10 times.
2. If no error is detected, do not replace any FRU.
3. If any error is detected, replace the FRU. Rerun the test to verify that there are no more errors.

Undetermined Problems

The diagnostic problems does not identify which adapter or device failed, which installed devices are incorrect, whether a short circuit is suspected, or whether the system is inoperative.

Follow these procedures to isolate the failing FRU (do not isolate non-defective FRU).

NOTE: Verify that all attached devices are supported by the computer.

NOTE: Verify that the power supply being used at the time of the failure is operating correctly. (See "Power System Check" on page 77):

1. Power-off the computer.
2. Visually check them for damage. If any problems are found, replace the FRU.
3. Remove or disconnect all of the following devices:
 - Non-Acer devices
 - Printer, mouse, and other external devices
 - Battery pack
 - Hard disk drive
 - DIMM
 - PC Cards
4. Power-on the computer.
5. Determine if the problem has changed.
6. If the problem does not recur, reconnect the removed devices one at a time until you find the failing FRU.
7. If the problem remains, replace the following FRU one at a time. Do not replace a non-defective FRU:
 - System board
 - LCD assembly

Jumper and Connector Locations

Top View

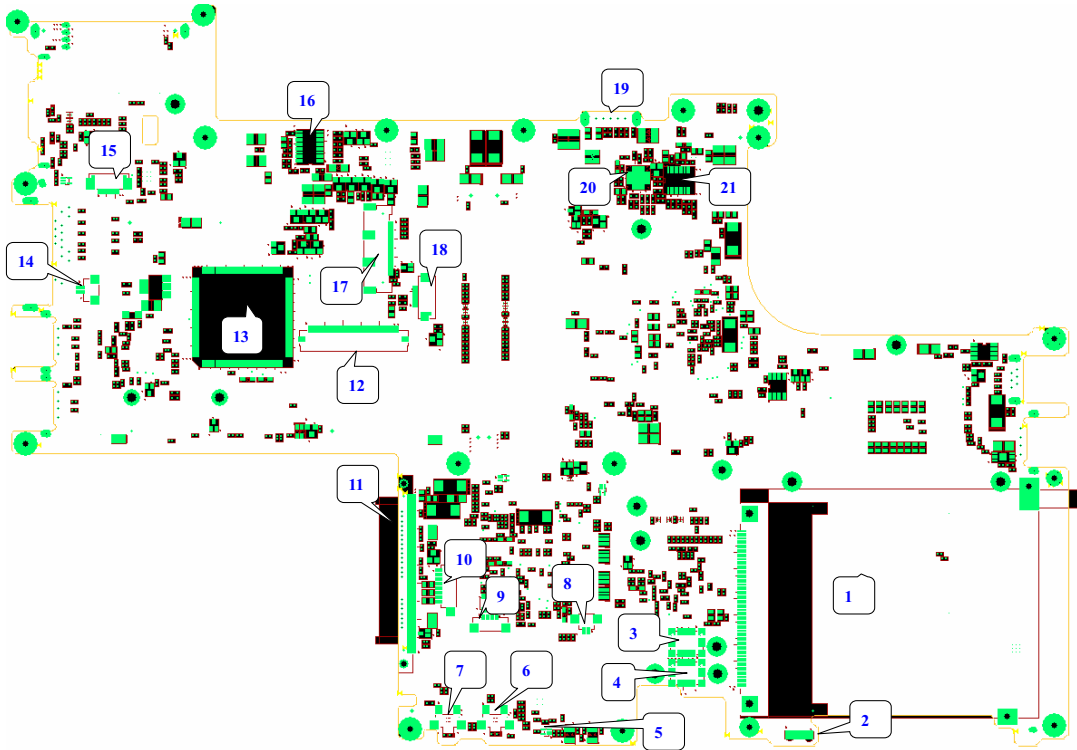

1	PCMCIA Connector	12	Keyboard Connector
2	FIR	13	EC Controller
3	Modem Board Connector	14	MDC Connector
4	Audio Board Connector	15	SW Board Connector
5	Power/Charger LED	16	3V/5V Converter IC
6	Wireless Switch	17	LCD/CCD Connector
7	Bluetooth Switch	18	Touchpad Connector
8	Internal Microphone Connector	19	Battery Connector
9	Internal Speaker Connector	20	Charger IC
10	Bluetooth Cable Connector	21	+1.05V Converter IC
11	SATA HDD Connector		

Bottom View

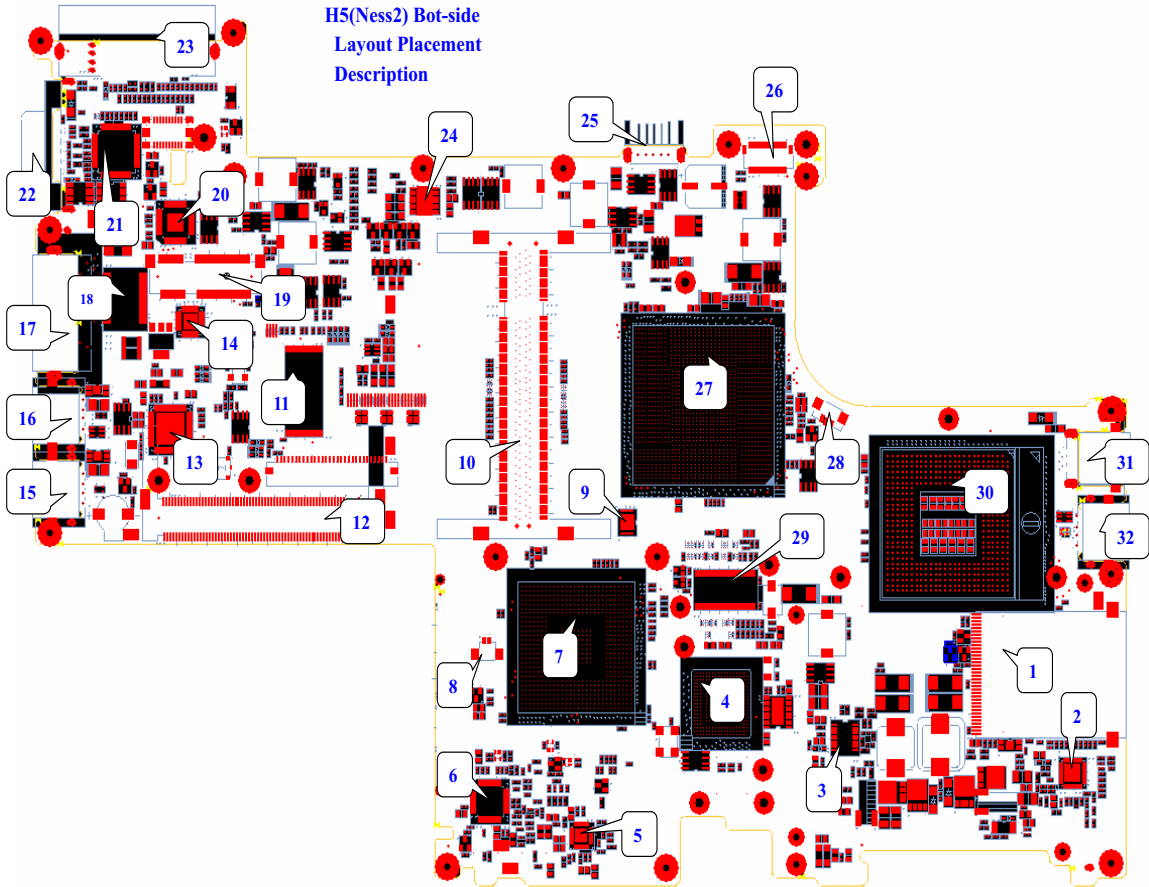

1	5-in1 Card Reader Connector	17	
2	CPU Power IC	18	
3	+1.5V Power IC	19	Mini Card Connector
4	Card Bus IC	20	DVI (CH7307C) IC
5	Audio AMP	21	SIO (PC87383) IC
6	Audio Codec AL883	22	VGA Connector
7	South Bridge ICH7-M	23	EZ dock Connector
8	RTC Battery	24	DDRII Power IC
9	G Sense	25	Battery Connector
10	DDRII soDIMM socket	26	DC-in Connector
11	BIOS	27	North Bridge 945GM
12	Mini PCI Connector	28	FAN Connector
13	LAN Controller	29	Clock Generator
14	LAN Switch	30	CPU
15	USB Connector	31	1394 Connector
16	USB Connector	32	USB Connector

FRU (Field Replaceable Unit) List

This chapter gives you the FRU (Field Replaceable Unit) listing in global configurations of TravelMate 3030/3040 series products. Refer to this chapter whenever ordering for parts to repair or for RMA (Return Merchandise Authorization).

Please note that WHEN ORDERING FRU PARTS, you should check the most up-to-date information available on your regional web or channel. For whatever reasons a part number change is made, it will not be noted on the printed Service Guide. For ACER AUTHORIZED SERVICE PROVIDERS, your Acer office may have a DIFFERENT part number code from those given in the FRU list of this printed Service Guide. You MUST use the local FRU list provided by your regional Acer office to order FRU parts for repair and service of customer machines.

NOTE: To scrap or to return the defective parts, you should follow the local government ordinance or regulations on how to dispose it properly, or follow the rules set by your regional Acer office on how to return it.

Exploded Diagram

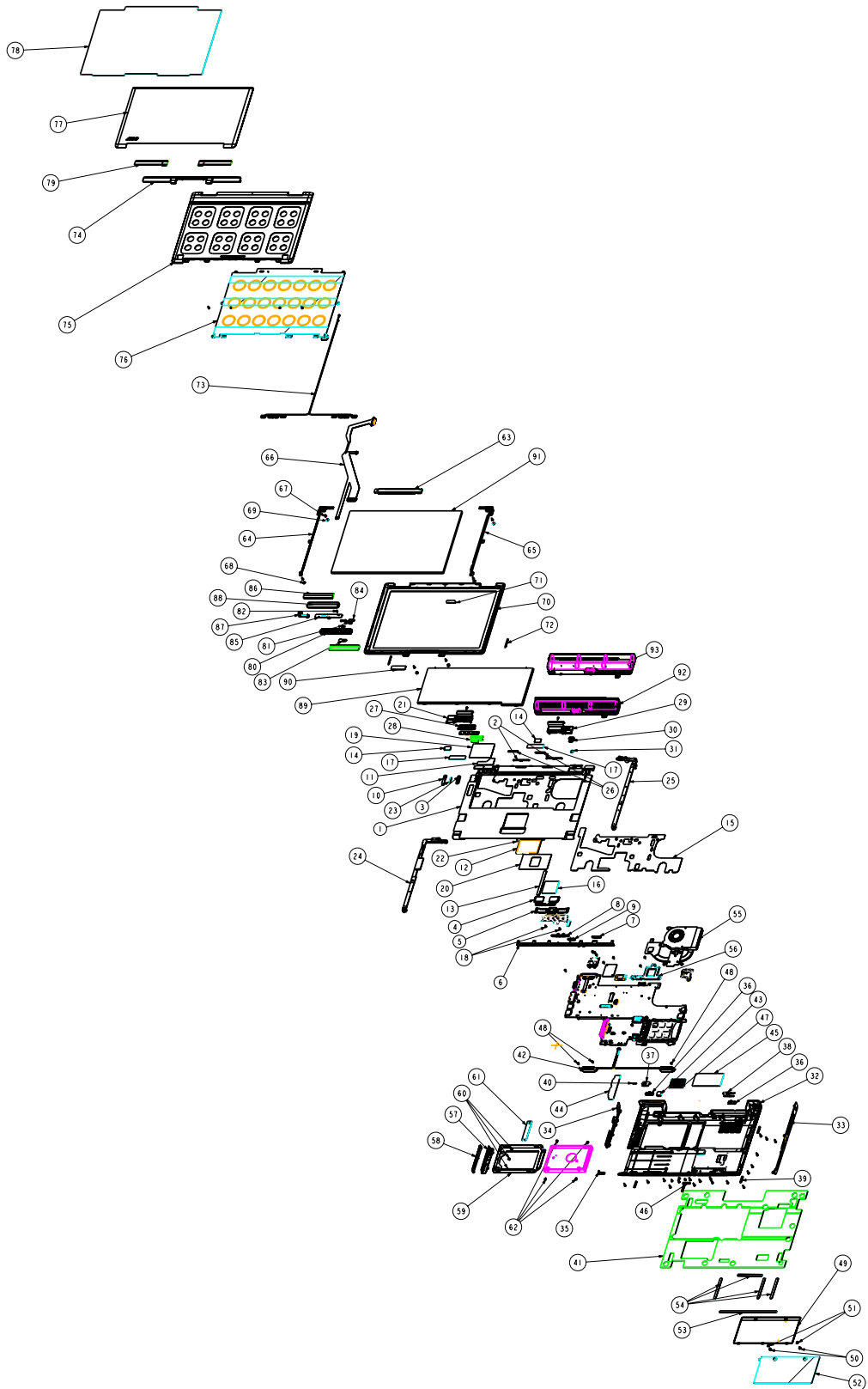

Item List

Item	Description	Q'ty	Item	Description	Q'ty
1	Top cover	1	51	E ring 5-2-0.41	2
2	Keyboard lock	2	52	RAM door protect	1
3	Function lens	1	53	RAM door gasket S1	1
4	TP button	1	54	RAM door gasket S2	4
5	4 way button	1	55	Thermal module	1
6	Front cover	1	56	CPU plate bracket	1
7	IR lens	1	57	HDD cover	1
8	Front button	1	58	HDD cover F	1
9	Charge lens	1	59	HDD bracket	1
10	VGA cap	1	60	Screw M2.5X3-l	3
11	Keyboard SP mylar	1	61	HDD bracket mylar	1
12	Touchpad	1	62	Screw M3X3.8	1
13	Cable Touchpad board	1	63	Inverter module	1
14	Top case keyboard Gasket	2	64	Hinge bracket L	1
15	Top mylar	1	65	Hinge bracket R	1
16	Touchpad kapton	1	66	Cable ZH2 AU 12.1 W/O CCD	1
17	Top case KB al foil	2	67	Screw M2X2.5-l	4
18	Screw M2X4-l	2	68	LCD bezel rubber	4
19	TP mylar	1	69	LCD rubber down	2
20	TP kapton	1	70	LCD bezel (AU)	1
21	Hinge cover L	1	71	LCD bezel logo	1
22	BU light mylar	1	72	Bezel mid rubber	2
23	Top sponge	1	74	Antenna	1
24	Hinge SP-L	1	75	LCD cover	1
25	Hinge SP-R	1	76	LCD cover shielding	1
26	Top case rubber	2	77	LCD pre coat cover	1
27	Function key	1	78	LCD cover protect	1
28	Hinge cover al foil	1	79	Ant cover protect	2
29	Hinge cover R	1	80	CCD front case	1
30	Power button	1	81	CCD lens	1
31	Hinge cover washer	1	82	Screw M1.6X3 l	1
32	Base case	1	83	CCD protect film	1
33	Base bezel R PCMCIA	1	84	CCD hinge	1
34	Base bezel L	1	85	Camera V-UBDOEM I	1
35	Base bezel F	1	86	CCD rear protect2	2
36	Battery button	2	87	Cable CCD assy	1
37	Battery latch L	1	88	CCD rear cover	1
38	Battery latch R	1	89	KB ZH2	1
39	Base rubber foot	4	90	CCD use label	1
40	HDD latch spring	1	91	LCD	1







Item List





Item	Description	Q'ty	Item	Description	Q'ty
41	Base protector mylar	1	92	Battery 3 cell	1
42	Speaker assy	1	93	Battery 6 cell	1
43	Audio gasket	1			
44	USB mesh	1			
45	Base flow mylar	1			
46	Base rubber foot F	1			
47	Base mesh	1			
48	Screw M2X4-l	3			
49	RAM door	1			
50	Fixed screw M2.5	2			

FRU List

NOTE: TravelMate 3030/3040 FRU list is not ready as the service guide released. We will update the FRU list as soon as possible.

CATEGORY	PARTNAME	DESCRIPTION	ACER PART NO.
ADAPTER			
	ADAPTER 65W 3 PIN Delta SADP-65KB DBRF LF	ZH2 ADPTER Delta S/P	AP.06501.010
	ADAPTER 65W 3 PIN LITE-ON PA1650-02 QY LF	ZH2 ADAPTER LITE-ON S.P.	AP.06503.013
BATTERY			
	BATTERY SANYO LI- ION 3S2P 6CELL 4800mAH	ZH1 6-CELL BATTERY S/P-SANYO	BT.00603.003
	BATTERY PANASONIC LI-ION 3S2P 6CELL 4800mAH	ZH1 6-CELL BATTERY S/P-MKE	BT.00605.001
	BATTERY SANYO LI- ION 3S1P 3CELL 2000mAH	ZH1 3-CELL BATTERY S/P-SANYO	BT.00303.002
	BATTERY PANASONIC CGR LI-ION 3S1P 3CELL 2000mAH	ZH1 3-CELL BATTERY S/P-CGR	BT.00305.001
BOARD			
	MODEM 56K (MDC)FOXCONN T60M845.02 EU	ZL8 MODEM 56K(MDC) EU S/P	54.TAKV7.001
	BLUETOOTH MODULE (T60H928.01)	ZC1 FOX BLUETOOTH(T60H928.0 1)S/P	54.TAXV7.001
	MINI PCI WIRELESS BOARD 802.11 A/B/G MOW2 INTEL MM872659	ZC1 W/L 3945ABG MOW2 S/P	KI.GLN01.002
	MINI PCI WIRELESS BOARD 802.11 A/B/G MOW1 INTEL MM872612	ZC1 W/L 3945ABG MOW1 S/P	KI.GLN01.001
	MINI PCI WIRELESS BOARD 802.11 A/B/G ROW INTEL MM874511	ZC1 W/L 3945ABG ROW S/P	KI.GLN01.003

CATEGORY	PARTNAME	DESCRIPTION	ACER PART NO.
	WIRELESS LAN BOARD 802.11BG INTEL WM3945AGBGGEN	ZC1 W/L 3945BG S/P	KI.GLN01.005
	FUNCTION BOARD (L)	ZH2 BUTTON BOARD S/ P	55.TATV7.001
	TOUCH PAD BOARD	ZH2 TOUCH PAD BOARD S/P	55.TATV7.002
	AUDIO BOARD	ZH2 AUDIO BOARD	55.TATV7.003
	DC BOARD	ZH2 DC BOARD	55.TATV7.004
CABLE			
	MODEM CABLE	ZH1 MODEM CABLE S/P	50.T74V7.001
	BLUETOOTH CABLE	ZH1 BOLUETOOTH CABLE S/P	50.T74V7.002
	FFC CABLE - TP/B TO MB	ZH1 FFC TP/B-MB S/P	50.T74V7.003
	FFC CABLE - FUNCTION/B TO MB	ZH1 FFC BUTTON/B-MB S/P	50.T74V7.004
	POWER CORD AF-S (INDIA)	ZL6A POWER CORD S/ P INDIA S.P.	27.A50V7.001
	POWER CORD AU W/ LABEL (3 PIN)	ZL6A POWER CORD S/ P-AU S.P.	27.A50V7.003
	POWER CORD SWISS 3 PIN	ZE1 POWER CORD 3P SWISS S.P.	27.A99V7.004
	POWER CORD AF (3 PIN)	ZI5 POWER CORD S/P- AF	27.T48V7.001



CATEGORY	PARTNAME	DESCRIPTION	ACER PART NO.
	POWER CORD ITALIAN 3PIN	EI2 POWER CORD 3P ITALY S.P.	27.A99V7.005
	POWER CORD DANISH (3 PIN)	ET2S POWER CORD SPARE PART-DANISH	27.A03V7.006
	POWER CORD US BSMI 3PIN	ZL3E POWER CORD S/ P-TWN	27.A99V7.002
	POWER CORD EU 1.8M 3PBLACK FM010008-010	PA2 ADP+POWER CORD(3P 90W W/ FPC)S/P	27.TATV7.001
	POWER CORD US 1.8M 3P BLACK FF0-920106	ZL3E POWER CORD S/ P- US	27.TATV7.002
	POWER CORD UK 1.8M 3P BLACK FP010008-013	ZC1 POWER CORD-US EU S/P	27.TATV7.003
	POWER CORD PRC 3P Y536B30001218008	EW1 POWER CODE (CH) ASSY (8 IN 1) S/P	27.TATV7.004
	POWER CORD ISRAEL 1.8M 3P BLK FZ0I0008-038 L-F	ZL6A POWER CORD S/ P-ISR S.P.	27.TATV7.005
CASE/COVER/BRACKET ASSEMBLY			
	"UPPER CASE ASSY W/ TP , TP CABLE"	ZH2 TOP COVER ASSY S/P	60.TATV7.001
	LOWER CASE ASSY W/ SPEAKER	ZH2 BASE CASE W/ PCMCIA ASSY S/P	60.TATV7.002
	HINGE COVER L W/ FUCTION BUTTON	ZH1 HINGE COVER-L S/ P	42.T74V7.001
	HINGE COVER R W/ POWER BUTTON	ZH1 HINGE COVER-R S/ P	42.T74V7.002

CATEGORY	PARTNAME	DESCRIPTION	ACER PART NO.
	RAM DOOR W/SCREW	ZH2 RAM DOOR S/P	42.TATV7.001
COMMUNICATION MODULE			
	WIRELESS ANTENNA (81.ED415.010)EU	ZH2 WIRELESS ANTENNA S/P	50.TATV7.001
COMBO MODULE	EXTERNAL COMBO MODULE PANASONIC UJDA-770	ZH1 KME COMBO ASSY S/P	KO.02406.014
COMBO MODULE	EXTERNAL COMBO MODULE LITEON SOSC-2483K LF	ZH1 LITE-ON COMBO ASSY S/P	KO.02409.014
DVD RW DRIVE	EXTERNAL DVD DUAL MODULE LITEON SOSW-833S LF	ZH1 LITE-ON DVD DUAL(D-L) ASSY S/P	KU.00804.020
DVD RW DRIVE	EXTERNAL DVD DUAL MODULE PANASONIC UJ-840 LF	ZH1 KME DVD DUAL (D- L) ASSY S/P	KU.00807.030
DVD RW DRIVE	EXTERNAL DVD SUPER MUJLTI MODULE LITEON SSM- 8515S LF	ZH2 DVD SUPER MULTI ASSY S/P	KU.00804.026
CABLE	EXTERNAL OPTICAL CABLE	"ZH2 CABLE ASSY ZH1- 1394 (6P/6P,3A) S/P"	50.T74V7.101
HDD/HARD DISK DRIVE	HDD 100G SEAGATE 2.5' 5.4K SATA 1.5G NCQ M2 ST9100824AS F/W 3.06	ZH2 HDD(100G)ST9100824A S S/P	KH.10001.005
HDD/HARD DISK DRIVE	"HDD 100G HGST 2.5' SATA 1.5G NCQMORAGA+HTS541 010G9SA00 FW:S60D,L"	ZH2 HDD(100GS)HTS541010 G9SA00 S/P	KH.10007.005
HDD/HARD DISK DRIVE	"HDD 120G SEAGATE 2.5' 5400RPM MERCURY 2 ST9120821A F/ W:3.04,LF"	ZH2 HDD(120G) ST9120821A S/P	KH.12001.015
HDD/HARD DISK DRIVE	"HDD 120G HGST 2.5' 5400RPM HAKONE-B F/ W : (ROHS),LF"	ZH2 HDD(80G)HTS541080G9 AT00 S/P	KH.12007.007
HDD/HARD DISK DRIVE	HDD 120G SEAGATE 2.5' 5.4K SATA 1.5G NCQ M2 ST9120821AS F/W 3.03	ZC1 HDD SEAGATE 120G S/P	KH.12001.016

CATEGORY	PARTNAME	DESCRIPTION	ACER PART NO.
HDD/HARD DISK DRIVE	"HDD 120G SEAGATE 2.5" 5400RPM SATA ST9120821AS LF MERCURY 2 FW:3.06"	ZH2 HDD(120G)ST9120821A S S/P	KH.12001.025
HDD/HARD DISK DRIVE	"HDD 120G TOSHIBA 2.5" 5.4K SATA1.5G W/ NCQ MK1234GSX LF TAURUS FW:AH001A"	ZH2 HDD(120G) MK1234GSX-CZK S/P	KH.12004.003
HDD/HARD DISK DRIVE	"HDD '80G SEAGATE 2.5' 5.4K SATA 1.5G NCQ M2 ST98823AS F/ W 3.06,LF"	ZH2 HDD(80G)ST98823AS S/ P	KH.08001.015
HDD/HARD DISK DRIVE	"HDD 80G HGST 2.5' 5.4K SATA 1.5G NCQ MORAGA+HTS541080G 9SA00,C60D"	ZB1 HDD 80GS HGST S/P	KH.08007.015
CASE/COVER/ BRACKET ASSEMBLY	HDD HOLDER	ZH1 HDD DOOR S/P	60.T74V7.003
KEYBOARD			
	KEYBOARD NORWAY	ZH2 K/B MODULE(NORWEGIAN) S/P	KB.T7407.016
	KEYBOARD HEBREW	ZH2 K/B MODULE(HEBREW) S/ P	KB.T7407.022
	KEYBOARD PORTUGUESE	ZH2 K/B MODULE(PORTUGUES E) S/P	KB.T7407.010
	KEYBOARD SWISS/G	ZH2 K/B MODULE(SWISS) S/P	KB.T7407.009
	KEYBOARD US INTERNATIONAL	ZH2 K/B MODULE(UI) S/ P	KB.T7407.026
	KEYBOARD ARABIC	ZH2 K/B MODULE(ARAB-EN) S/P	KB.T7407.011



CATEGORY	PARTNAME	DESCRIPTION	ACER PART NO.
	KEYBOARD SPANISH	ZH2 K/B MODULE(SPANISH) S/P	KB.T7407.001
	KEYBOARD DANISH	ZH2K/B MODULE(DANISH) S/P	KB.T7407.017
	KEYBOARD CANADIAN FRENCH	ZH2 K/B MODULE(FRA- CAN) S/P	KB.T7407.019
	KEYBOARD JAPAN	ZH2 K/B MODULE(JAPAN) S/P	KB.T7407.020
	KEYBOARD ITALIAN	ZH2 K/B MODULE(ITALIAN) S/P	KB.T7407.007
	KEYBOARD GERMAN	ZH2 K/B MODULE(GERMAN) S/P	KB.T7407.006
	KEYBOARD FRENCH	ZH2 K/B MODULE(FRENCH) S/P	KB.T7407.008
	KEYBOARD UK	ZH2 K/B MODULE(UK) S/P	KB.T7407.005
	KEYBOARD SWEDEN	ZH2 K/B MODULE(SWEDISH) S/ P	KB.T7407.013
	KEYBOARD BELGIUM	ZH2 K/B MODULE(BELGIUM) S/P	KB.T7407.012
	KEYBOARD TURKISH	ZH2K/B MODULE(TURKISH) S/P	KB.T7407.018
	KEYBOARD RUSSIAN	ZH2 K/B MODULE(RUSSIAN) S/P	KB.T7407.023

CATEGORY	PARTNAME	DESCRIPTION	ACER PART NO.
	KEYBOARD BRAZILIAN PROTUGESE	ZH2 K/B MODULE(BRAZIL) S/P	KB.T7407.003
	KEYBOARD HUNGAIAN	ZH2 K/B MODULE(HUNGARIAN) S/P	KB.T7407.015
	KEYBOARD CZECH	ZH2 K/B MODULE(CZECH) S/P	KB.T7407.014
	KEYBOARD THAI	ZH2 K/B MODULE(THAI) S/P	KB.T7407.002
	KEYBOARD GREEK	ZH2 K/B MODULE(GREEK) S/P	KB.T7407.021
	KEYBOARD CHINESE	ZH2 K/B MODULE(TAIWAN) S/P	KB.T7407.027
	KEYBOARD SLOVENIA	ZH2 K/B MODULE SLOVENIA S/P	KB.T7407.024
	KEYBOARD CHINA	ZH2 K/B MODULE(CHINA) S/P	
	KEYBOARD DUTCH	ZH2 K/B MODULE(DUTCH) S/P	
	KEYBOARD POLAND	ZH2 K/B MODULE(POLAND) S/P	
	KEYBOARD LA	ZH2 K/B MODULE(LA) S/P	
	KEYBOARD KOREAN	ZH2 K/B MODULE(KOREAN) S/P	
	KEYBOARD ICELAND	ZH2 K/B MODULE(ICELAND) S/P	
LCD			
LCD	LCD 12.1 LCD MODULE GLARE W/ CCD ASSY	ZH2 12.1 LCD W/ CCD(GLARE) ASSY S/P	6M.TATV7.001
LCD	LCD 12.1 IN. TFT WXGA AU B121EW01 V.3 GLARE	ZH1 12.1" WXGA AU B121EW01 V.3 GLA S/P	LK.12105.003
LCD	LCD 12.1 IN. TFT WXGA QDI QD12TL02-01 GLARE	ZH1 12.1" WXGA QD12TL02 QDI GLA S/P	LK.12109.002
LCD	LCD 12.1 IN. TFT WXGA CMO N121I3-L01 GLARE	"ZH2 LCD(TFT)12.1" N121I3-L01(GLARE) S/P"	LK.1210D.007
	LCD INVERTER BOARD	ZH1 12 IN.WXGA LCD INVERTER S/P	19.TATV7.001

CATEGORY	PARTNAME	DESCRIPTION	ACER PART NO.
	LCD CABLE ASSY FOR CCD	ZH2 CABLE ASSY AUO WXGA S/P	50.TATV7.002
	LCD BRACKET W/ HINGE - L	ZH2 HINGE-BKT-L (AU) S/P	33.TATV7.001
	LCD BRACKET W/ HINGE - R	ZH2 HINGE-BKT-R(AU) S/P	33.TATV7.002
	LCD COVER W/ ANTENNA/PRECOAT/ CCD ASSY	ZH2 LCD COVER W/ PRECOAT/CCD ASSY S/P	60.TATV7.003
	LCD BEZEL ASSY W/ LOGO FOR CCD	ZH2 LCD BEZEL ASSY S/P	60.TATV7.004
	CCD MODULE	ZH2 LCD CCD FRONT CASE ASSY S/P	57.TATV7.001

CATEGORY	PARTNAME	DESCRIPTION	ACER PART NO.
	LCD 12.1 LCD MODULE NON-GLARE W/ CCD ASSY	ZH2 12.1 LCD W/ CCD (NON-GL) ASSY S/P	6M.TATV7.002
	LCD 12.1 IN. TFT WXGA AU B121EW01 V.5 NON GLARE	"ZH2 LCD(TFT)12.1""B121EW 01 V.5(WXGA) S/P"	LK.12105.004
	LCD 12.1 IN. TFT WXGA QDI QD12TL02-03 NON GLARE	"ZH2 LCD12.1"" NO-GLE QD12TL02 WXGA S/P"	LK.12109.001
	LCD 12.1 IN. TFT WXGA CMO N121I3-L02 NON GLARE	"ZH2 LCD(TFT) 12.1""N121I3-L02(NON-GL) S/P"	LK.1210D.006
BOARD	LCD INVERTER BOARD	ZH1 12 IN.WXGA LCD INVERTER S/P	19.TATV7.001
CABLE	LCD CABLE ASSY FOR CCD	ZH2 CABLE ASSY AUO WXGA S/P	50.TATV7.002
CASE/COVER/ BRACKET ASSEMBLY	LCD BRACKET W/ HINGE - L	ZH2 HINGE-BKT-L (AU) S/P	33.TATV7.001
CASE/COVER/ BRACKET ASSEMBLY	LCD BRACKET W/ HINGE - R	ZH2 HINGE-BKT-R(AU) S/P	33.TATV7.002
CASE/COVER/ BRACKET ASSEMBLY	LCD COVER W/ ANTENNA/PRECOAT/ CCD ASSY	ZH2 LCD COVER W/ PRECOAT/CCD ASSY S/ P	60.TATV7.003
CASE/COVER/ BRACKET ASSEMBLY	LCD BEZEL ASSY W/ LOGO FOR CCD	ZH2 LCD BEZEL ASSY S/P	60.TATV7.004
CCD MODULE	CCD MODULE	ZH2 LCD CCD FRONT CASE ASSY S/P	57.TATV7.001
LCD	LCD MODULE 12.1 IN. GLARE W/O CCD ASSY	ZH2 12.1 LCD W/O CCD GLA ASSY S/P	6M.TATV7.003
LCD	LCD 12.1 IN. TFT WXGA AU B121EW01 V.3 GLARE	ZH1 12.1" WXGA AU B121EW01 V.3 GLA S/P	LK.12105.003
LCD	LCD 12.1 IN. TFT WXGA QDI QD12TL02-01 GLARE	ZH1 12.1" WXGA QD12TL02 QDI GLA S/P	LK.12109.002
LCD	LCD 12.1 IN. TFT WXGA CMO N121I3-L01 GLARE	"ZH2 LCD(TFT)12.1"" N121I3-L01(GLARE) S/ P"	LK.1210D.007
BOARD	LCD INVERTER BOARD	ZH1 12 IN.WXGA LCD INVERTER S/P	19.TATV7.001
CABLE	LCD CABLE ASSY W/O CCD	"ZH2 LCD CABLE AU 12.1"" W/O CCD S/P"	50.TATV7.003
CASE/COVER/ BRACKET ASSEMBLY	LCD BRACKET W/ HINGE - L	ZH2 HINGE-BKT-L (AU) S/P	33.TATV7.001

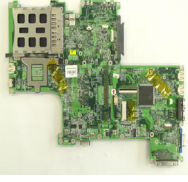
CATEGORY	PARTNAME	DESCRIPTION	ACER PART NO.
CASE/COVER/ BRACKET ASSEMBLY	LCD BRACKET W/ HINGE - R	ZH2 HINGE-BKT-R(AU) S/P	33.TATV7.002
CASE/COVER/ BRACKET ASSEMBLY	LCD COVER W/ ANTENNA W/O CCD ASSY	ZH2 LCD COVER W/O CCD ASSY S/P	60.TATV7.005
CASE/COVER/ BRACKET ASSEMBLY	LCD BEZEL ASSY W/ LOGO W/O CCD	"ZH1 12"" LCD BEZEL W/LOG S/P"	60.TATV7.006
LCD	LCD MODULE 12.1 IN. NON GLARE W/O CCD ASSY	ZH2 12.1 LCD W/O CCD NON-GL ASSY S/P	6M.TATV7.004
LCD	LCD 12.1 IN. TFT WXGA AU B121EW01 V.5 NON GLARE	"ZH2 LCD(TFT)12.1""B121EW 01 V.5(WXGA) S/P"	LK.12105.004
LCD	LCD 12.1 IN. TFT WXGA QDI QD12TL02-03 NON GLARE	"ZH2 LCD12.1"" NO-GLE QD12TL02 WXGA S/P"	LK.12109.001
LCD	LCD 12.1 IN. TFT WXGA CMO N121I3-L02 NON GLARE	"ZH2 LCD(TFT) 12.1""N121I3-L02(NON- GL) S/P"	LK.1210D.006
BOARD	LCD INVERTER BOARD	ZH1 12 IN.WXGA LCD INVERTER S/P	19.TATV7.001
CABLE	LCD CABLE ASSY W/O CCD	"ZH2 LCD CABLE AU 12.1"" W/O CCD S/P"	50.TATV7.003
CASE/COVER/ BRACKET ASSEMBLY	LCD BRACKET W/ HINGE - L	ZH2 HINGE-BKT-L (AU) S/P	33.TATV7.001
CASE/COVER/ BRACKET ASSEMBLY	LCD BRACKET W/ HINGE - R	ZH2 HINGE-BKT-R(AU) S/P	33.TATV7.002
CASE/COVER/ BRACKET ASSEMBLY	LCD COVER W/ ANTENNA W/O CCD ASSY	ZH2 LCD COVER W/O CCD ASSY S/P	60.TATV7.005
CASE/COVER/ BRACKET ASSEMBLY	LCD BEZEL ASSY W/ LOGO W/O CCD	"ZH1 12"" LCD BEZEL W/LOG S/P"	60.TATV7.006
MAINBOARD			

CATEGORY	PARTNAME	DESCRIPTION	ACER PART NO.
	MAINBOARD SATA / T2300/945GM/5 in 1/ GLAN	"ZH2 MB ASSY(Y2.0,SA,MC,G) S/P"	LB.TAT06.001
	MAINBOARD SATA / T2400/945GM/5 in 1/ GLAN	"ZH2 MB ASSY (Y1.67,SA,MC,G) S/P"	LB.TAT06.002
	MAINBOARD SATA / T2500/945GM/5 in 1/ GLAN	"ZH2 MB ASSY(Y1.83,SA,MC,G) S/P"	LB.TAT06.003
	MAINBOARD SATA / T2600/945GM/5 in 1/ GLAN	"ZH2 MB ASSY(Y2.16,7A,MC,G) S/P"	LB.TAT06.004
MEMORY			
MEMORY	"MEMORY INFINEON, DDRII 533 256M HYS64T32000HDL-3.7-A"	ZB1 RAM DDRII5 256M INF S/P	KN.25602.023
MEMORY	"MEMORY NANYA, DDRII533 256MB NT256T64UH4A1FN-37B (PB-FREE)"	ZB1 RAM DDRII5 256M NANYA S/P	KN.25603.029
MEMORY	"MEMORY HYNIX, DDRII 533 256MB HYMP532S64P6-C4"	ZB1 RAM DDRII 533 256MB HYNIX S/P	KN.2560G.006
MEMORY	"MEMORY INFINEON, DDRII 533 512MB HYS64T64020HDL-3.7-A (0.11U/G)"	ZH2 RAM(512M)HYS64T64020HDL-3.7-A S/P	KN.51202.021
MEMORY	"MEMORY NANYA, DDRII533 512MB NT512T64UH8A1FN-37B (PB-FREE)"	ZB1 RAM(512M)DDR2 NANYA S/P	KN.51203.023
MEMORY	"MEMORY SAMSUNG, DDRII533 512MB M470T6554CZ3-CD500"	ZB1 RAM DDRII533 512MB SAMSUNG S/P	KN.5120B.015
MEMORY	"MEMORY HYNIX, DDRII 533 512MB HYMP564S64P6-C4"	ZE1 RAM DDRII5 512MB HY S/P	KN.5120G.005
	THERMAL MODULE	ZH2 THERMAL MODULE S/P	60.TATV7.007
SPEAKER	SPEAKER ASSY	ZH2 SPEAKER ASSY SPB2410-ZH2-4 EU S/P	23.TATV7.001

CATEGORY	PARTNAME	DESCRIPTION	ACER PART NO.
MISCELLANEOUS W/O CCD	"LCD BEZEL RUBBER (GAZH1003,REV3A) "	ZH2 LCD RUBER-UPPER S/P	47.TATV7.001
MISCELLANEOUS W/O CCD	"LCD BEZEL RUBBER (GAZH1003,REV3A) W/O CCD"	ZH1 LCD RUBER-DWON S/P	47.TATV7.002
MISCELLANEOUS W/CCD	"LCD BEZEL RUBBER (GAZH2003,REV3A)"	ZH2 LCD RUBER-DWON S/P	47.TATV7.003
MISCELLANEOUS W/O CCD	"LCD GASKET (GBZH1011, REV3A)"	"ZH2 LCD GASKET (GBZH1011, REV3A) S/P"	47.TATV7.004
SCREW	SCREW MS2.0X4.0	ET2S SCREW MS2.0X4.0 SPARE PART S/P	86.A03V7.018
SCREW	SCREW M2.0*2.5-I(NI)(NYLOK)	EI2 SCREW M2.0*2.5-I(NI)(NYLOK) KIT S/P	86.TADV7.001
SCREW	SCREW M2.0*5-I(BNI)(NYLOK)D4 T0.	SCREW M2.0*5-I(BNI)(NYLOK)D4 T0.	86.TATV7.001
SCREW	SCREW M2.0*7.0-I(NI)(NYLOK)	SCREW M2.0*7.0-I(NI)(NYLOK)	86.TATV7.002
SCREW	"SCREW M3.0*3.8(I)-NIH-J(4.6,0.3)"	"SCREW M3.0*3.8(I)-NIH-J(4.6,0.3)"	86.TATV7.003
SCREW	SCREW M2.5*6.0-I(NI)(NYLOK)	SCREW M2.5*6.0-I(NI)(NYLOK)	86.TATV7.004

Model Definition and Configuration

TravelMate 3030 Series

Model	Country	Description	CPU	LCD	DIMM 1	HDD 1 (GB)	ODD	Wireless LAN	Battery	2nd Battery
TM3033N WTCi	Australia/ New Zealand	TM3033N WTCi LINPUSAU 1 UMASC 1*512/80/ BT/3H/ 5R_abg_1. 3C_AL	CDT230 0E	N12.1W XGA	SO512M BII6	N80GB5. 4KS	NCB24X 6P1394	INT3945 ABG_M OW1	3CELL2. 0H	
TM3034N WTCi	Singapore	TM3034N WTCi LINPUSSG 1 UMASC 1*512/80/ BT/3H/ 5R_abg_1. 3C_AL	CDT240 0	N12.1W XGA	SO512M BII6	N80GB5. 4KS	NCB24X 6P1394	INT3945 ABG_M OW2	3CELL2. 0H	
TM3035N WTCi	Singapore	TM3035N WTCi LINPUSSG 1 UMASC 1*512/100/ BT/6L/ 5R_abg_1. 3C_AL	CDT250 0	N12.1W XGA	SO512M BII6	N100GB 5.4KS	NCB24X 6P1394	INT3945 ABG_M OW2	6CELL2. 4	
TM3036N WTMi	Singapore	TM3036N WTMi LINPUSSG 1 UMASC 1*512/120/ BT/6L/ 5R_abg_1. 3C_AL	CDT260 0	N12.1W XGA	SO512M BII5	N120GB 5.4KS	NSM8X6 P1394	INT3945 ABG_M OW2	6CELL2. 4	
TM3037N WTMi	Singapore	TM3037N WTMi LINPUSSG 1 UMASC 1*1G/160/ BT/6L/ 5R_abg_1. 3C_AL	CDT270 0	N12.1W XGA	SO1GBII 6	N160GB 5.4KS	NSM8X6 P1394	INT3945 ABG_M OW2	6CELL2. 4	
TM3032W TMi	GCTWN	TM3032W TMi XPHTC1 UMASC 1*512/120/ BT/6L+3H/ 5R/ CB_abg_1. 3C_AL	CDT230 0E	N12.1W XGAG	SO512M BII5	N120GB 5.4KS	NSM8X6 P1394	INT3945 ABG_M OW1	6CELL2. 4	3CELL2. 0H

TravelMate 3040 Series

Model	Country	Description	CPU	LCD	DIMM 1	DIMM 2	HDD 1 (GB)	ODD	Wireless LAN	BT	Battery	2nd Battery
TM3043WTM i	Belgium	TM3043WTM i XPPBE1 UMASC 1*512/100/ BT/6L+3H/ 5R_abg_1.3C _AL	C2DT55 00	N12.1 WXGA	SO512 MBII5	N	N100 GB5.4 KS	NSM8 X6P13 94	INT3945 ABG_M OW2	FOX_BR M_2.0	6CELL2. 4	3CELL2. 0H
TM3043WTM i	Middle East	TM3043WTM i XPPAR1 UMASC 1*512/100/ BT/6L+3H/ 5R_bg_1.3C_ AL	C2DT55 00	N12.1 WXGA	SO512 MBII5	N	N100 GB5.4 KS	NSM8 X6P13 94	INT3945 BG	FOX_BR M_2.0	6CELL2. 4	3CELL2. 0H
TM3043WTM i	Belgium	TM3043WTM i XPPBE1 UMASC 2*512/120/ BT/6L+3H/ 5R_abg_VP_ 1.3C_AL	C2DT55 00	N12.1 WXGA	SO512 MBII5	SO512 MBII5	N120 GB5.4 KS	NSM8 X6P13 94	INT3945 ABG_M OW2	FOX_BR M_2.0	6CELL2. 4	3CELL2. 0H
TM3043WTM i	Middle East	TM3043WTM i XPPAR1 UMASC 2*512/120/ BT/6L+3H/ 5R_bg_VP_1 .3C_AL	C2DT55 00	N12.1 WXGA	SO512 MBII5	SO512 MBII5	N120 GB5.4 KS	NSM8 X6P13 94	INT3945 BG	FOX_BR M_2.0	6CELL2. 4	3CELL2. 0H
TM3043WTM i	Eastern Europe	TM3043WTM i XPPCS2 UMASC 2*512/120/ BT/6L+3H/ 5R_abg_VP_ 1.3C_AL	C2DT55 00	N12.1 WXGA	SO512 MBII5	SO512 MBII5	N120 GB5.4 KS	NSM8 X6P13 94	INT3945 ABG_M OW2	FOX_BR M_2.0	6CELL2. 4	3CELL2. 0H
TM3043WTM i	Eastern Europe	TM3043WTM i XPPCS2 UMASC 1*512/100/ BT/6L+3H/ 5R_abg_1.3C _AL	C2DT55 00	N12.1 WXGA	SO512 MBII5	N	N100 GB5.4 KS	NSM8 X6P13 94	INT3945 ABG_M OW2	FOX_BR M_2.0	6CELL2. 4	3CELL2. 0H
TM3043WTM i	Denmark	TM3043WTM i XPPDK1 UMASC 1*512/100/ BT/6L+3H/ 5R_abg_1.3C _AL	C2DT55 00	N12.1 WXGA	SO512 MBII5	N	N100 GB5.4 KS	NSM8 X6P13 94	INT3945 ABG_M OW2	FOX_BR M_2.0	6CELL2. 4	3CELL2. 0H
TM3043WTM i	Germany	TM3043WTM i XPPDE7 UMASC 1*512/100/ BT/6L+3H/ 5R_abg_1.3C _AL	C2DT55 00	N12.1 WXGA	SO512 MBII5	N	N100 GB5.4 KS	NSM8 X6P13 94	INT3945 ABG_M OW2	FOX_BR M_2.0	6CELL2. 4	3CELL2. 0H
TM3043WTM i	Germany	TM3043WTM i XPPDE7 UMASC 2*512/120/ BT/6L+3H/ 5R_abg_VP_ 1.3C_AL	C2DT55 00	N12.1 WXGA	SO512 MBII5	SO512 MBII5	N120 GB5.4 KS	NSM8 X6P13 94	INT3945 ABG_M OW2	FOX_BR M_2.0	6CELL2. 4	3CELL2. 0H

Model	Country	Description	CPU	LCD	DIMM 1	DIMM 2	HDD 1 (GB)	ODD	Wireless LAN	BT	Battery	2nd Battery
TM3043WTM i	Greece	TM3043WTM i XPPPEL3 UMASC 1*512/100/ BT/6L+3H/ 5R_abg_1.3C _AL	C2DT55 00	N12.1 WXGA	SO512 MBII5	N	N100 GB5.4 KS	NSM8 X6P13 94	INT3945 ABG_M OW2	FOX_BR M_2.0	6CELL2. 4	3CELL2. 0H
TM3043WTM i	Denmark	TM3043WTM i XPPDK1 UMASC 2*512/120/ BT/6L+3H/ 5R_abg_VP_ 1.3C_AL	C2DT55 00	N12.1 WXGA	SO512 MBII5	SO512 MBII5	N120 GB5.4 KS	NSM8 X6P13 94	INT3945 ABG_M OW2	FOX_BR M_2.0	6CELL2. 4	3CELL2. 0H
TM3043WTM i	Greece	TM3043WTM i XPPPEL3 UMASC 2*512/120/ BT/6L+3H/ 5R_abg_VP_ 1.3C_AL	C2DT55 00	N12.1 WXGA	SO512 MBII5	SO512 MBII5	N120 GB5.4 KS	NSM8 X6P13 94	INT3945 ABG_M OW2	FOX_BR M_2.0	6CELL2. 4	3CELL2. 0H
TM3043WTM i	Spain	TM3043WTM i XPPESA UMASC 2*512/120/ BT/6L+3H/ 5R_abg_VP_ 1.3C_AL	C2DT55 00	N12.1 WXGA	SO512 MBII5	SO512 MBII5	N120 GB5.4 KS	NSM8 X6P13 94	INT3945 ABG_M OW2	FOX_BR M_2.0	6CELL2. 4	3CELL2. 0H
TM3043WTM i	Spain	TM3043WTM i XPPESA UMASC 1*512/100/ BT/6L+3H/ 5R_abg_1.3C _AL	C2DT55 00	N12.1 WXGA	SO512 MBII5	N	N100 GB5.4 KS	NSM8 X6P13 94	INT3945 ABG_M OW2	FOX_BR M_2.0	6CELL2. 4	3CELL2. 0H
TM3043WTM i	Israel	TM3043WTM i XPPIS1 UMASC 1*512/100/ BT/6L+3H/ 5R_bg_1.3C _AL	C2DT55 00	N12.1 WXGA	SO512 MBII5	N	N100 GB5.4 KS	NSM8 X6P13 94	INT3945 BG	FOX_BR M_2.0	6CELL2. 4	3CELL2. 0H
TM3043WTM i	Eastern Europe	TM3043WTM i XPPHU6 UMASC 1*512/100/ BT/6L+3H/ 5R_abg_1.3C _AL	C2DT55 00	N12.1 WXGA	SO512 MBII5	N	N100 GB5.4 KS	NSM8 X6P13 94	INT3945 ABG_M OW2	FOX_BR M_2.0	6CELL2. 4	3CELL2. 0H
TM3043WTM i	France	TM3043WTM i XPPFRA UMASC 1*512/100/ BT/6L+3H/ 5R_abg_1.3C _AL	C2DT55 00	N12.1 WXGA	SO512 MBII5	N	N100 GB5.4 KS	NSM8 X6P13 94	INT3945 ABG_M OW2	FOX_BR M_2.0	6CELL2. 4	3CELL2. 0H
TM3043WTM i	Italy	TM3043WTM i XPPIT1 UMASC 1*512/100/ BT/6L+3H/ 5R_abg_1.3C _AL	C2DT55 00	N12.1 WXGA	SO512 MBII5	N	N100 GB5.4 KS	NSM8 X6P13 94	INT3945 ABG_M OW2	FOX_BR M_2.0	6CELL2. 4	3CELL2. 0H
TM3043WTM i	France	TM3043WTM i XPPFRA UMASC 2*512/120/ BT/6L+3H/ 5R_abg_VP_ 1.3C_AL	C2DT55 00	N12.1 WXGA	SO512 MBII5	SO512 MBII5	N120 GB5.4 KS	NSM8 X6P13 94	INT3945 ABG_M OW2	FOX_BR M_2.0	6CELL2. 4	3CELL2. 0H

Model	Country	Description	CPU	LCD	DIMM 1	DIMM 2	HDD 1 (GB)	ODD	Wireless LAN	BT	Battery	2nd Battery
TM3043WTM i	Eastern Europe	TM3043WTM i XPPHU6 UMASC 2*512/120/ BT/6L+3H/ 5R_abg_VP_1.3C_AL	C2DT5500	N12.1 WXGA	SO512 MBII5	SO512 MBII5	N120 GB5.4 KS	NSM8 X6P13 94	INT3945 ABG_M OW2	FOX_BR M_2.0	6CELL2.4	3CELL2.0H
TM3043WTM i	Israel	TM3043WTM i XPPIS1 UMASC 2*512/120/ BT/6L+3H/ 5R_bg_VP_1.3C_AL	C2DT5500	N12.1 WXGA	SO512 MBII5	SO512 MBII5	N120 GB5.4 KS	NSM8 X6P13 94	INT3945 BG	FOX_BR M_2.0	6CELL2.4	3CELL2.0H
TM3043WTM i	France	TM3043WTM i XPPFRA UMASC 2*512/120/ BT/6L+3H/ 5R_abg_1.3C_AL	C2DT5500	N12.1 WXGA	SO512 MBII5	SO512 MBII5	N120 GB5.4 KS	NSM8 X6P13 94	INT3945 ABG_M OW2	FOX_BR M_2.0	6CELL2.4	3CELL2.0H
TM3043WTM i	Italy	TM3043WTM i XPPIT1 UMASC 2*512/120/ BT/6L+3H/ 5R_abg_VP_1.3C_AL	C2DT5500	N12.1 WXGA	SO512 MBII5	SO512 MBII5	N120 GB5.4 KS	NSM8 X6P13 94	INT3945 ABG_M OW2	FOX_BR M_2.0	6CELL2.4	3CELL2.0H
TM3043WTM i	Eastern Europe	TM3043WTM i XPPPL6 UMASC 2*512/120/ BT/6L+3H/ 5R_abg_VP_1.3C_AL	C2DT5500	N12.1 WXGA	SO512 MBII5	SO512 MBII5	N120 GB5.4 KS	NSM8 X6P13 94	INT3945 ABG_M OW2	FOX_BR M_2.0	6CELL2.4	3CELL2.0H
TM3043WTM i	Holland	TM3043WTM i XPPNL1 UMASC 2*512/120/ BT/6L+3H/ 5R_abg_VP_1.3C_AL	C2DT5500	N12.1 WXGA	SO512 MBII5	SO512 MBII5	N120 GB5.4 KS	NSM8 X6P13 94	INT3945 ABG_M OW1	FOX_BR M_2.0	6CELL2.4	3CELL2.0H
TM3043WTM i	Norway	TM3043WTM i XPPNO1 UMASC 2*512/120/ BT/6L+3H/ 5R_abg_VP_1.3C_AL	C2DT5500	N12.1 WXGA	SO512 MBII5	SO512 MBII5	N120 GB5.4 KS	NSM8 X6P13 94	INT3945 ABG_M OW2	FOX_BR M_2.0	6CELL2.4	3CELL2.0H
TM3043WTM i	Holland	TM3043WTM i XPPNL1 UMASC 1*512/100/ BT/6L+3H/ 5R_abg_1.3C_AL	C2DT5500	N12.1 WXGA	SO512 MBII5	N	N100 GB5.4 KS	NSM8 X6P13 94	INT3945 ABG_M OW1	FOX_BR M_2.0	6CELL2.4	3CELL2.0H
TM3043WTM i	Norway	TM3043WTM i XPPNO1 UMASC 1*512/100/ BT/6L+3H/ 5R_abg_1.3C_AL	C2DT5500	N12.1 WXGA	SO512 MBII5	N	N100 GB5.4 KS	NSM8 X6P13 94	INT3945 ABG_M OW2	FOX_BR M_2.0	6CELL2.4	3CELL2.0H
TM3043WTM i	Eastern Europe	TM3043WTM i XPPPL6 UMASC 1*512/100/ BT/6L+3H/ 5R_abg_1.3C_AL	C2DT5500	N12.1 WXGA	SO512 MBII5	N	N100 GB5.4 KS	NSM8 X6P13 94	INT3945 ABG_M OW2	FOX_BR M_2.0	6CELL2.4	3CELL2.0H

Model	Country	Description	CPU	LCD	DIMM 1	DIMM 2	HDD 1 (GB)	ODD	Wireless LAN	BT	Battery	2nd Battery
TM3043WTM i	Portugal	TM3043WTM i XPPPT1 UMASC 1*512/100/ BT/6L+3H/ 5R_abg_1.3C_AL	C2DT5500	N12.1 WXGA	SO512 MBII5	N	N100 GB5.4 KS	NSM8 X6P13 94	INT3945 ABG_M OW2	FOX_BR M_2.0	6CELL2.4	3CELL2.0H
TM3043WTM i	Slovenia/ Croatia	TM3043WTM i XPPSLO1 UMASC 1*512/100/ BT/6L+3H/ 5R_abg_1.3C_AL	C2DT5500	N12.1 WXGA	SO512 MBII5	N	N100 GB5.4 KS	NSM8 X6P13 94	INT3945 ABG_M OW2	FOX_BR M_2.0	6CELL2.4	3CELL2.0H
TM3043WTM i	Russia	TM3043WTM i XPPRU2 UMASC 1*512/100/ BT/6L+3H/ 5R_abg_1.3C_AL	C2DT5500	N12.1 WXGA	SO512 MBII5	N	N100 GB5.4 KS	NSM8 X6P13 94	INT3945 ABG_M OW2	FOX_BR M_2.0	6CELL2.4	3CELL2.0H
TM3043WTM i	South Africa	TM3043WTM i XPPSA1 UMASC 1*512/100/ BT/6L+3H/ 5R_abg_1.3C_AL	C2DT5500	N12.1 WXGA	SO512 MBII5	N	N100 GB5.4 KS	NSM8 X6P13 94	INT3945 ABG_M OW2	FOX_BR M_2.0	6CELL2.4	3CELL2.0H
TM3043WTM i	Russia	TM3043WTM i XPPRU2 UMASC 2*512/120/ BT/6L+3H/ 5R_abg_VP_1.3C_AL	C2DT5500	N12.1 WXGA	SO512 MBII5	SO512 MBII5	N120 GB5.4 KS	NSM8 X6P13 94	INT3945 ABG_M OW2	FOX_BR M_2.0	6CELL2.4	3CELL2.0H
TM3043WTM i	South Africa	TM3043WTM i XPPSA1 UMASC 2*512/120/ BT/6L+3H/ 5R_abg_VP_1.3C_AL	C2DT5500	N12.1 WXGA	SO512 MBII5	SO512 MBII5	N120 GB5.4 KS	NSM8 X6P13 94	INT3945 ABG_M OW2	FOX_BR M_2.0	6CELL2.4	3CELL2.0H
TM3043WTM i	Slovenia/ Croatia	TM3043WTM i XPPSLO1 UMASC 2*512/120/ BT/6L+3H/ 5R_abg_VP_1.3C_AL	C2DT5500	N12.1 WXGA	SO512 MBII5	SO512 MBII5	N120 GB5.4 KS	NSM8 X6P13 94	INT3945 ABG_M OW2	FOX_BR M_2.0	6CELL2.4	3CELL2.0H
TM3043WTM i	Portugal	TM3043WTM i XPPPT1 UMASC 2*512/120/ BT/6L+3H/ 5R_abg_VP_1.3C_AL	C2DT5500	N12.1 WXGA	SO512 MBII5	SO512 MBII5	N120 GB5.4 KS	NSM8 X6P13 94	INT3945 ABG_M OW2	FOX_BR M_2.0	6CELL2.4	3CELL2.0H
TM3043WTM i	Turkey	TM3043WTM i XPPTR1 UMASC 2*512/120/ BT/6L+3H/ 5R_abg_VP_1.3C_AL	C2DT5500	N12.1 WXGA	SO512 MBII5	SO512 MBII5	N120 GB5.4 KS	NSM8 X6P13 94	INT3945 ABG_M OW2	FOX_BR M_2.0	6CELL2.4	3CELL2.0H
TM3043WTM i	Switzerland	TM3043WTM i XPPSW5 UMASC 2*512/120/ BT/6L+3H/ 5R_abg_VP_1.3C_AL	C2DT5500	N12.1 WXGA	SO512 MBII5	SO512 MBII5	N120 GB5.4 KS	NSM8 X6P13 94	INT3945 ABG_M OW2	FOX_BR M_2.0	6CELL2.4	3CELL2.0H

Model	Country	Description	CPU	LCD	DIMM 1	DIMM 2	HDD 1 (GB)	ODD	Wireless LAN	BT	Battery	2nd Battery
TM3043WTMi	UK	TM3043WTMi XPPUK1 UMASC 2*512/120/BT/6L+3H/5R_abg_VP_1.3C_AL	C2DT5500	N12.1 WXGA	SO512 MBI15	SO512 MBI15	N120 GB5.4 KS	NSM8 X6P13 94	INT3945 ABG_M OW2	FOX_BR M_2.0	6CELL2.4	3CELL2.0H
TM3043WTMi	Switzerland	TM3043WTMi XPPSW5 UMASC 1*512/100/BT/6L+3H/5R_abg_1.3C_AL	C2DT5500	N12.1 WXGA	SO512 MBI15	N	N100 GB5.4 KS	NSM8 X6P13 94	INT3945 ABG_M OW2	FOX_BR M_2.0	6CELL2.4	3CELL2.0H
TM3043WTMi	UK	TM3043WTMi XPPUK1 UMASC 1*512/100/BT/6L+3H/5R_abg_1.3C_AL	C2DT5500	N12.1 WXGA	SO512 MBI15	N	N100 GB5.4 KS	NSM8 X6P13 94	INT3945 ABG_M OW2	FOX_BR M_2.0	6CELL2.4	3CELL2.0H
TM3043WTMi	Turkey	TM3043WTMi XPPTR1 UMASC 1*512/100/BT/6L+3H/5R_abg_1.3C_AL	C2DT5500	N12.1 WXGA	SO512 MBI15	N	N100 GB5.4 KS	NSM8 X6P13 94	INT3945 ABG_M OW2	FOX_BR M_2.0	6CELL2.4	3CELL2.0H
TM3043WTMi	Sweden/Finland	TM3043WTMi XPPSV1 UMASC 2*512/120/BT/6L+3H/5R_abg_VP_1.3C_AL	C2DT5500	N12.1 WXGA	SO512 MBI15	SO512 MBI15	N120 GB5.4 KS	NSM8 X6P13 94	INT3945 ABG_M OW2	FOX_BR M_2.0	6CELL2.4	3CELL2.0H
TM3043WTMi	Sweden/Finland	TM3043WTMi XPPSV1 UMASC 1*512/100/BT/6L+3H/5R_abg_1.3C_AL	C2DT5500	N12.1 WXGA	SO512 MBI15	N	N100 GB5.4 KS	NSM8 X6P13 94	INT3945 ABG_M OW2	FOX_BR M_2.0	6CELL2.4	3CELL2.0H
TM3043WTCi	China	TM3043WTCi XPHSC7 UMASC 1*512/80/6L+3H/5R_abg_1.3C_AL	C2DT5500	N12.1 WXGA	SO512 MBI15	N	N80G B5.4K S	NCB2 4X6P1 394	INT3945 ABG_R OW	N	6CELL2.4	3CELL2.0H
TM3043WTCi	Hong Kong	TM3043WTCi XPHHK9 UMASC 1*512/80/6L+3H/5R_abg_1.3C_AL	C2DT5500	N12.1 WXGA	SO512 MBI15	N	N80G B5.4K S	NCB2 4X6P1 394	INT3945 ABG_M OW1	N	6CELL2.4	3CELL2.0H
TM3043WTMi	GCTWN	TM3043WTMi XPHTC1 UMASC 1*1G/120/BT/6L+3H/5R/CB_abg_VP_1.3C_AL	C2DT5500	N12.1 WXGA G	SO1G BII15	N	N120 GB5.4 KS	NSM8 X6P13 94	INT3945 ABG_M OW1	FOX_BR M_2.0	6CELL2.4	3CELL2.0H
TM3043WTMi	Sweden/Finland	TM3043WTMi XPHSV1 UMASC 1*512/80/BT/6L+3H/5R_abg_1.3C_AL	C2DT5500	N12.1 WXGA	SO512 MBI15	N	N80G B5.4K S	NSM8 X6P13 94	INT3945 ABG_M OW2	FOX_BR M_2.0	6CELL2.4	3CELL2.0H

Model	Country	Description	CPU	LCD	DIMM 1	DIMM 2	HDD 1 (GB)	ODD	Wireless LAN	BT	Battery	2nd Battery
TM3043NWT Mi	Sweden/Finland	TM3043NWT Mi LINPUSSV1 UMASC 1*512/80/BT/ 6L+3H/ 5R_abg_1.3C _AL	C2DT5500	N12.1 WXGA	SO512 MBI15	N	N80G B5.4K S	NSM8 X6P13 94	INT3945 ABG_M OW2	FOX_BR M_2.0	6CELL2.4	3CELL2.0H
TM3043WTM i	Sweden/Finland	TM3043WTM i XPSSV1 UMASC 1*512/80/BT/ 6L+3H/ 5R_abg_1.3C _AL	C2DT5500	N12.1 WXGA	SO512 MBI15	N	N80G B5.4K S	NSM8 X6P13 94	INT3945 ABG_M OW2	FOX_BR M_2.0	6CELL2.4	3CELL2.0H
TM3043WTCi	South Africa	TM3043WTCi XPHSA1 UMASC 1*512/80/BT/ 3H/5R/ CB_abg_1.3 C_AL	C2DT5500	N12.1 WXGA G	SO512 MBI15	N	N80G B5.4K S	NCB2 4X6P1 394	INT3945 ABG_M OW2	FOX_BR M_2.0	3CELL2.0H	
TM3044WTM i	South Africa	TM3044WTM i XPHSA1 UMASC 2*512/120/ BT/6L+3H/ 5R_abg_VP_1.3C _AL	C2DT5600	N12.1 WXGA	SO512 MBI15	SO512 MBI15	N120 GB5.4 KS	NSM8 X6P13 94	INT3945 ABG_M OW2	FOX_BR M_2.0	6CELL2.4	3CELL2.0H
TM3045WTCi	Australia/New Zealand	TM3045WTCi XPHAU1 UMASC 1*512/80/BT/ 6L/5R/ CB_abg_1.3 C_AL	C2DT7200	N12.1 WXGA G	SO512 MBI16	N	N80G B5.4K S	NCB2 4X6P1 394	INT3945 ABG_M OW1	FOX_BR M_2.0	6CELL2.4	
TM3046WTCi	Australia/New Zealand	TM3046WTCi XPHAU1 UMASC 1*1G/100/BT/ 6L/ 5R_abg_1.3C _AL	C2DT7400	N12.1 WXGA	SO1G BII15	N	N100 GB5.4 KS	NCB2 4X6P1 394	INT3945 ABG_M OW1	FOX_BR M_2.0	6CELL2.4	
TM3047WTM i	Australia/New Zealand	TM3047WTM i XPHAU1 UMASC 1*1G/100/BT/ 6L/ 5R_abg_1.3C _AL	C2DT7600	N12.1 WXGA	SO1G BII16	N	N100 GB5.4 KS	NSM8 X6P13 94	INT3945 ABG_M OW1	FOX_BR M_2.0	6CELL2.4	
TM3043WTNi	Australia/New Zealand	TM3043WTNi XPPAU1 UMASC 1*512/80/BT/ 6L+3H/ 5R_abg_1.3C _AL	C2DT5500	N12.1 WXGA	SO512 MBI15	N	N80G B5.4K S	N	INT3945 ABG_M OW1	FOX_BR M_2.0	6CELL2.4	3CELL2.0H
TM3044WTM i	Singapore	TM3044WTM i XPHWSG21 W UMASC 2*512/160/ BT/6L+3H/ 5R/ CB_abg_VP_1.3C _AL	C2DT5600	N12.1 WXGA G	SO512 MBI15	SO512 MBI15	N160 GB5.4 KS	NSM8 X6P13 94	INT3945 ABG_M OW2	FOX_BR M_2.0	6CELL2.4	3CELL2.0H

Model	Country	Description	CPU	LCD	DIMM 1	DIMM 2	HDD 1 (GB)	ODD	Wireless LAN	BT	Battery	2nd Battery
TM3044WTMi	Philippines	TM3044WTMi XPHPH1 UMASC 2*512/160/ BT/6L+3H/ 5R/ CB_abg_VP_1.3C_AL	C2DT5600	N12.1 WXGAG	SO512 MBI15	SO512 MBI15	N160 GB5.4 KS	NSM8 X6P13 94	INT3945 ABG_M OW2	FOX_BR M_2.0	6CELL2.4	3CELL2.0H
TM3044WTMi	Malaysia	TM3044WTMi XPHMA2 UMASC 2*512/160/ BT/6L+3H/ 5R/ CB_abg_VP_1.3C_AL	C2DT5600	N12.1 WXGAG	SO512 MBI15	SO512 MBI15	N160 GB5.4 KS	NSM8 X6P13 94	INT3945 ABG_M OW1	FOX_BR M_2.0	6CELL2.4	3CELL2.0H
TM3044WTMi	Vietnam	TM3044WTMi XPHVN1 UMASC 2*512/160/ BT/6L+3H/ 5R/ CB_abg_VP_1.3C_AL	C2DT5600	N12.1 WXGAG	SO512 MBI15	SO512 MBI15	N160 GB5.4 KS	NSM8 X6P13 94	INT3945 ABG_M OW1	FOX_BR M_2.0	6CELL2.4	3CELL2.0H
TM3044WTMi	India	TM3044WTMi XPPIL1 UMASC 2*512/160/ BT/6L+3H/ 5R/ CB_abg_VP_1.3C_AL	C2DT5600	N12.1 WXGAG	SO512 MBI15	SO512 MBI15	N160 GB5.4 KS	NSM8 X6P13 94	INT3945 ABG_M OW1	FOX_BR M_2.0	6CELL2.4	3CELL2.0H
TM3044WTMi	Singapore	TM3044WTMi XPPWSG21 W UMASC 2*512/160/ BT/6L+3H/ 5R/ CB_abg_VP_1.3C_AL	C2DT5600	N12.1 WXGAG	SO512 MBI15	SO512 MBI15	N160 GB5.4 KS	NSM8 X6P13 94	INT3945 ABG_M OW1	FOX_BR M_2.0	6CELL2.4	3CELL2.0H
TM3044WTMi	Vietnam	TM3044WTMi XPPVN1 UMASC 2*512/160/ BT/6L+3H/ 5R/ CB_abg_VP_1.3C_AL	C2DT5600	N12.1 WXGAG	SO512 MBI15	SO512 MBI15	N160 GB5.4 KS	NSM8 X6P13 94	INT3945 ABG_M OW1	FOX_BR M_2.0	6CELL2.4	3CELL2.0H
TM3044WTMi	Indonesia	TM3044WTMi XPPIN1 UMASC 2*512/160/ BT/6L+3H/ 5R/ CB_abg_VP_1.3C_AL	C2DT5600	N12.1 WXGAG	SO512 MBI15	SO512 MBI15	N160 GB5.4 KS	NSM8 X6P13 94	INT3945 ABG_M OW1	FOX_BR M_2.0	6CELL2.4	3CELL2.0H
TM3044WTMi	Philippines	TM3044WTMi XPPPH1 UMASC 2*512/160/ BT/6L+3H/ 5R/ CB_abg_VP_1.3C_AL	C2DT5600	N12.1 WXGAG	SO512 MBI15	SO512 MBI15	N160 GB5.4 KS	NSM8 X6P13 94	INT3945 ABG_M OW1	FOX_BR M_2.0	6CELL2.4	3CELL2.0H
TM3044WTMi	Malaysia	TM3044WTMi XPPMA2 UMASC 2*512/160/ BT/6L+3H/ 5R/ CB_abg_VP_1.3C_AL	C2DT5600	N12.1 WXGAG	SO512 MBI15	SO512 MBI15	N160 GB5.4 KS	NSM8 X6P13 94	INT3945 ABG_M OW1	FOX_BR M_2.0	6CELL2.4	3CELL2.0H

Model	Country	Description	CPU	LCD	DIMM 1	DIMM 2	HDD 1 (GB)	ODD	Wireless LAN	BT	Battery	2nd Battery
TM3043WTM i	Australia /New Zealand	TM3043WTM i XPPAU1 UMASC 1*512/80/BT/6L+3H/5R_abg_VP_1.3C_AL	C2DT5500	N12.1 WXGA	SO512 MBII5	N	N80G B5.4K S	NSM8 X6P13 94	INT3945 ABG_M OW1	FOX_BR M_2.0	6CELL2.4	3CELL2.0H
TM3043WTM i	Australia /New Zealand	TM3043WTM i XPHAU1 UMASC 1*512/80/BT/6L+3H/5R_abg_VP_1.3C_AL	C2DT5500	N12.1 WXGA	SO512 MBII5	N	N80G B5.4K S	NSM8 X6P13 94	INT3945 ABG_M OW1	FOX_BR M_2.0	6CELL2.4	3CELL2.0H
TM3044WTM i	Singapore	TM3044WTM i XPHWSG21 W UMASC 2*512/120/BT/6L+3H/5R/ CB_abg_VP_1.3C_AL	C2DT5600	N12.1 WXGA G	SO512 MBII5	SO512 MBII5	N120 GB5.4 KS	NSM8 X6P13 94	INT3945 ABG_M OW1	FOX_BR M_2.0	6CELL2.4	3CELL2.0H
TM3044WTM i	USA/ Canada	TM3044WTM i XPPEN1 UMASC 2*512/160/BT/6L+3H/5R/ CB_abg_VP_1.3C_AL	C2DT5600	N12.1 WXGA G	SO512 MBII5	SO512 MBII5	N160 GB5.4 KS	NSM8 X6P13 94	INT3945 ABG_M OW1	FOX_BR M_2.0	6CELL2.4	3CELL2.0H
TM3044WTM i	USA/ Canada	TM3044WTM i XPPFR1 UMASC 2*512/160/BT/6L+3H/5R/ CB_abg_VP_1.3C_AL	C2DT5600	N12.1 WXGA G	SO512 MBII5	SO512 MBII5	N160 GB5.4 KS	NSM8 X6P13 94	INT3945 ABG_M OW1	FOX_BR M_2.0	6CELL2.4	3CELL2.0H
TM3044WTM i	ACLA-Spanish	TM3044WTM i XPPES1 UMASC 2*512/160/BT/6L+3H/5R/ CB_abg_VP_1.3C_AL	C2DT5600	N12.1 WXGA G	SO512 MBII5	SO512 MBII5	N160 GB5.4 KS	NSM8 X6P13 94	INT3945 ABG_M OW1	FOX_BR M_2.0	6CELL2.4	3CELL2.0H
TM3044WTM i	ACLA-Portuguese	TM3044WTM i XPPXC1 UMASC 2*512/160/BT/6L+3H/5R/ CB_abg_VP_1.3C_AL	C2DT5600	N12.1 WXGA G	SO512 MBII5	SO512 MBII5	N160 GB5.4 KS	NSM8 X6P13 94	INT3945 ABG_M OW2	FOX_BR M_2.0	6CELL2.4	3CELL2.0H
TM3043WTM i	Belgium	TM3043WTM i XPPBE1 UMASC 1*512/120/BT/6L+3H/5R_abg_1.3C_AL	C2DT5500	N12.1 WXGA	SO512 MBII5	N	N120 GB5.4 KS	NSM8 X6P13 94	INT3945 ABG_M OW2	FOX_BR M_2.0	6CELL2.4	3CELL2.0H
TM3043WTM i	Eastern Europe	TM3043WTM i XPPCS2 UMASC 1*512/120/BT/6L+3H/5R_abg_1.3C_AL	C2DT5500	N12.1 WXGA	SO512 MBII5	N	N120 GB5.4 KS	NSM8 X6P13 94	INT3945 ABG_M OW2	FOX_BR M_2.0	6CELL2.4	3CELL2.0H

Model	Country	Description	CPU	LCD	DIMM 1	DIMM 2	HDD 1 (GB)	ODD	Wireless LAN	BT	Battery	2nd Battery
TM3043WTM i	Middle East	TM3043WTM i XPPAR1 UMASC 1*512/120/ BT/6L+3H/ 5R_abg_1.3C _AL	C2DT55 00	N12.1 WXGA	SO512 MBII5	N	N120 GB5.4 KS	NSM8 X6P13 94	INT3945 ABG_M OW2	FOX_BR M_2.0	6CELL2. 4	3CELL2. 0H
TM3043WTM i	Greece	TM3043WTM i XPPEL3 UMASC 1*512/120/ BT/6L+3H/ 5R_abg_1.3C _AL	C2DT55 00	N12.1 WXGA	SO512 MBII5	N	N120 GB5.4 KS	NSM8 X6P13 94	INT3945 ABG_M OW2	FOX_BR M_2.0	6CELL2. 4	3CELL2. 0H
TM3043WTM i	Spain	TM3043WTM i XPPESA UMASC 1*512/120/ BT/6L+3H/ 5R_abg_1.3C _AL	C2DT55 00	N12.1 WXGA	SO512 MBII5	N	N120 GB5.4 KS	NSM8 X6P13 94	INT3945 ABG_M OW2	FOX_BR M_2.0	6CELL2. 4	3CELL2. 0H
TM3043WTM i	Israel	TM3043WTM i XPPIS1 UMASC 1*512/120/ BT/6L+3H/ 5R_abg_1.3C _AL	C2DT55 00	N12.1 WXGA	SO512 MBII5	N	N120 GB5.4 KS	NSM8 X6P13 94	INT3945 ABG_M OW2	FOX_BR M_2.0	6CELL2. 4	3CELL2. 0H
TM3043WTM i	Eastern Europe	TM3043WTM i XPPHU6 UMASC 1*512/120/ BT/6L+3H/ 5R_abg_1.3C _AL	C2DT55 00	N12.1 WXGA	SO512 MBII5	N	N120 GB5.4 KS	NSM8 X6P13 94	INT3945 ABG_M OW2	FOX_BR M_2.0	6CELL2. 4	3CELL2. 0H
TM3043WTM i	France	TM3043WTM i XPPFRA UMASC 1*512/120/ BT/6L+3H/ 5R_abg_1.3C _AL	C2DT55 00	N12.1 WXGA	SO512 MBII5	N	N120 GB5.4 KS	NSM8 X6P13 94	INT3945 ABG_M OW2	FOX_BR M_2.0	6CELL2. 4	3CELL2. 0H
TM3043WTM i	Germany	TM3043WTM i XPPDE7 UMASC 1*512/120/ BT/6L+3H/ 5R_abg_1.3C _AL	C2DT55 00	N12.1 WXGA	SO512 MBII5	N	N120 GB5.4 KS	NSM8 X6P13 94	INT3945 ABG_M OW2	FOX_BR M_2.0	6CELL2. 4	3CELL2. 0H
TM3043WTM i	Denmark	TM3043WTM i XPPDK1 UMASC 1*512/120/ BT/6L+3H/ 5R_abg_1.3C _AL	C2DT55 00	N12.1 WXGA	SO512 MBII5	N	N120 GB5.4 KS	NSM8 X6P13 94	INT3945 ABG_M OW2	FOX_BR M_2.0	6CELL2. 4	3CELL2. 0H
TM3043WTM i	South Africa	TM3043WTM i XPPSA1 UMASC 1*512/120/ BT/6L+3H/ 5R_abg_1.3C _AL	C2DT55 00	N12.1 WXGA	SO512 MBII5	N	N120 GB5.4 KS	NSM8 X6P13 94	INT3945 ABG_M OW2	FOX_BR M_2.0	6CELL2. 4	3CELL2. 0H
TM3043WTM i	Holland	TM3043WTM i XPPNL1 UMASC 1*512/120/ BT/6L+3H/ 5R_abg_1.3C _AL	C2DT55 00	N12.1 WXGA	SO512 MBII5	N	N120 GB5.4 KS	NSM8 X6P13 94	INT3945 ABG_M OW2	FOX_BR M_2.0	6CELL2. 4	3CELL2. 0H

Model	Country	Description	CPU	LCD	DIMM 1	DIMM 2	HDD 1 (GB)	ODD	Wireless LAN	BT	Battery	2nd Battery
TM3043WTM i	Norway	TM3043WTM i XPPNO1 UMASC 1*512/120/ BT/6L+3H/ 5R_abg_1.3C _AL	C2DT55 00	N12.1 WXGA	SO512 MBII5	N	N120 GB5.4 KS	NSM8 X6P13 94	INT3945 ABG_M OW2	FOX_BR M_2.0	6CELL2. 4	3CELL2. 0H
TM3043WTM i	Russia	TM3043WTM i XPPRU2 UMASC 1*512/120/ BT/6L+3H/ 5R_abg_1.3C _AL	C2DT55 00	N12.1 WXGA	SO512 MBII5	N	N120 GB5.4 KS	NSM8 X6P13 94	INT3945 ABG_M OW2	FOX_BR M_2.0	6CELL2. 4	3CELL2. 0H
TM3043WTM i	Eastern Europe	TM3043WTM i XPPPL6 UMASC 1*512/120/ BT/6L+3H/ 5R_abg_1.3C _AL	C2DT55 00	N12.1 WXGA	SO512 MBII5	N	N120 GB5.4 KS	NSM8 X6P13 94	INT3945 ABG_M OW2	FOX_BR M_2.0	6CELL2. 4	3CELL2. 0H
TM3043WTM i	Portugal	TM3043WTM i XPPPT1 UMASC 1*512/120/ BT/6L+3H/ 5R_abg_1.3C _AL	C2DT55 00	N12.1 WXGA	SO512 MBII5	N	N120 GB5.4 KS	NSM8 X6P13 94	INT3945 ABG_M OW2	FOX_BR M_2.0	6CELL2. 4	3CELL2. 0H
TM3043WTM i	Italy	TM3043WTM i XPPIT1 UMASC 1*512/120/ BT/6L+3H/ 5R_abg_1.3C _AL	C2DT55 00	N12.1 WXGA	SO512 MBII5	N	N120 GB5.4 KS	NSM8 X6P13 94	INT3945 ABG_M OW2	FOX_BR M_2.0	6CELL2. 4	3CELL2. 0H
TM3043WTM i	Turkey	TM3043WTM i XPPTR1 UMASC 1*512/120/ BT/6L+3H/ 5R_abg_1.3C _AL	C2DT55 00	N12.1 WXGA	SO512 MBII5	N	N120 GB5.4 KS	NSM8 X6P13 94	INT3945 ABG_M OW2	FOX_BR M_2.0	6CELL2. 4	3CELL2. 0H
TM3043WTM i	Slovenia/ Croatia	TM3043WTM i XPPSLO1 UMASC 1*512/120/ BT/6L+3H/ 5R_abg_1.3C _AL	C2DT55 00	N12.1 WXGA	SO512 MBII5	N	N120 GB5.4 KS	NSM8 X6P13 94	INT3945 ABG_M OW2	FOX_BR M_2.0	6CELL2. 4	3CELL2. 0H
TM3043WTM i	Switzerla nd	TM3043WTM i XPPSW5 UMASC 1*512/120/ BT/6L+3H/ 5R_abg_1.3C _AL	C2DT55 00	N12.1 WXGA	SO512 MBII5	N	N120 GB5.4 KS	NSM8 X6P13 94	INT3945 ABG_M OW2	FOX_BR M_2.0	6CELL2. 4	3CELL2. 0H
TM3043WTM i	UK	TM3043WTM i XPPUK1 UMASC 1*512/120/ BT/6L+3H/ 5R_abg_1.3C _AL	C2DT55 00	N12.1 WXGA	SO512 MBII5	N	N120 GB5.4 KS	NSM8 X6P13 94	INT3945 ABG_M OW2	FOX_BR M_2.0	6CELL2. 4	3CELL2. 0H
TM3043WTM i	Sweden/ Finland	TM3043WTM i XPPSV1 UMASC 1*512/120/ BT/6L+3H/ 5R_abg_1.3C _AL	C2DT55 00	N12.1 WXGA	SO512 MBII5	N	N120 GB5.4 KS	NSM8 X6P13 94	INT3945 ABG_M OW2	FOX_BR M_2.0	6CELL2. 4	3CELL2. 0H

Model	Country	Description	CPU	LCD	DIMM 1	DIMM 2	HDD 1 (GB)	ODD	Wireless LAN	BT	Battery	2nd Battery
TM3043NWT Mi	Thailand	TM3043NWT Mi LINPUSH2 UMASC 2*512/120/ BT/6L+3H/ 5R/ CB_bg_1.3C _AL	C2DT5500	N12.1 WXGA G	SO512 MBII5	SO512 MBII5	N120 GB5.4 KS	NSM8 X6P13 94	INT3945 BG	FOX_BR M_2.0	6CELL2. 4	3CELL2. 0H
TM3043WTM i	UK	TM3043WTM i XPPUK1 UMASC 2*512/120/ BT/6L+3H/ 5R_abg_1.3C _AL	C2DT5500	N12.1 WXGA	SO512 MBII5	SO512 MBII5	N120 GB5.4 KS	NSM8 X6P13 94	INT3945 ABG_M OW2	FOX_BR M_2.0	6CELL2. 4	3CELL2. 0H
TM3043WTM i	Norway	TM3043WTM i XPPNO1 UMASC 2*1G/120/BT/ 6L+3H/ 5R_abg_VP_ 1.3C_AL	C2DT5500	N12.1 WXGA	SO1G BII5	SO1G BII5	N120 GB5.4 KS	NSM8 X6P13 94	INT3945 ABG_M OW2	FOX_BR M_2.0	6CELL2. 4	3CELL2. 0H
TM3043WTM i	Israel	TM3043WTM i XPPIS1 UMASC 2*1G/120/BT/ 6L+3H/ 5R_bg_1.3C_ AL	C2DT5500	N12.1 WXGA	SO1G BII5	SO1G BII5	N120 GB5.4 KS	NSM8 X6P13 94	INT3945 BG	FOX_BR M_2.0	6CELL2. 4	3CELL2. 0H
TM3043WTM i	Greece	TM3043WTM i XPPEL3 UMASC 2*1G/120/BT/ 6L+3H/ 5R_abg_1.3C _AL	C2DT5500	N12.1 WXGA	SO1G BII5	SO1G BII5	N120 GB5.4 KS	NSM8 X6P13 94	INT3945 ABG_M OW2	FOX_BR M_2.0	6CELL2. 4	3CELL2. 0H
TM3043WTM i	Italy	TM3043WTM i XPPIT1 UMASC 2*1G/120/BT/ 6L+3H/ 5R_abg_1.3C _AL	C2DT5500	N12.1 WXGA	SO1G BII5	SO1G BII5	N120 GB5.4 KS	NSM8 X6P13 94	INT3945 ABG_M OW2	FOX_BR M_2.0	6CELL2. 4	3CELL2. 0H
TM3043WTM i	Germany	TM3043WTM i XPPDE7 UMASC 1*512/120/ BT/6L+3H/ 5R_abg_VP_ 1.3C_AL	C2DT5500	N12.1 WXGA	SO512 MBII5	N	N120 GB5.4 KS	NSM8 X6P13 94	INT3945 ABG_M OW2	FOX_BR M_2.0	6CELL2. 4	3CELL2. 0H
TM3043WTM i	Russia	TM3043WTM i XPPRU2 UMASC 1*1G/120/BT/ 6L+3H/ 5R_abg_VP_ 1.3C_AL	C2DT5500	N12.1 WXGA	SO1G BII5	N	N120 GB5.4 KS	NSM8 X6P13 94	INT3945 ABG_M OW2	FOX_BR M_2.0	6CELL2. 4	3CELL2. 0H
TM3043WTM i	UK	TM3043WTM i XPPUK1 UMASC 1*1G/120/BT/ 6L+3H/ 5R_abg_VP_ 1.3C_AL	C2DT5500	N12.1 WXGA	SO1G BII5	N	N120 GB5.4 KS	NSM8 X6P13 94	INT3945 ABG_M OW2	FOX_BR M_2.0	6CELL2. 4	3CELL2. 0H
TM3043WTM i	Greece	TM3043WTM i XPPEL1 UMASC 1*1G/120/BT/ 6L+3H/ 5R_abg_1.3C _AL	C2DT5500	N12.1 WXGA	SO1G BII5	N	N120 GB5.4 KS	NSM8 X6P13 94	INT3945 ABG_M OW2	FOX_BR M_2.0	6CELL2. 4	3CELL2. 0H

Model	Country	Description	CPU	LCD	DIMM 1	DIMM 2	HDD 1 (GB)	ODD	Wireless LAN	BT	Battery	2nd Battery
TM3043WTM i	Israel	TM3043WTM i XPPIS1 UMASC 1*1G/120/BT/ 6L+3H/ 5R_bg_1.3C_ _AL	C2DT55 00	N12.1 WXGA	SO1G BII5	N	N120 GB5.4 KS	NSM8 X6P13 94	INT3945 BG	FOX_BR M_2.0	6CELL2. 4	3CELL2. 0H
TM3043WTM i	Italy	TM3043WTM i XPPIT1 UMASC 1*1G/120/BT/ 6L+3H/ 5R_abg_1.3C_ _AL	C2DT55 00	N12.1 WXGA	SO1G BII5	N	N120 GB5.4 KS	NSM8 X6P13 94	INT3945 ABG_M OW2	FOX_BR M_2.0	6CELL2. 4	3CELL2. 0H
TM3043WTM i	France	TM3043WTM i XPPFRA UMASC 1*1G/120/BT/ 6L+3H/ 5R_abg_1.3C_ _AL	C2DT55 00	N12.1 WXGA	SO1G BII5	N	N120 GB5.4 KS	NSM8 X6P13 94	INT3945 ABG_M OW2	FOX_BR M_2.0	6CELL2. 4	3CELL2. 0H
TM3043WTM i	Eastern Europe	TM3043WTM i XPPCS1 UMASC 1*1G/120/BT/ 6L+3H/ 5R_abg_VP_ 1.3C_AL	C2DT55 00	N12.1 WXGA	SO1G BII5	N	N120 GB5.4 KS	NSM8 X6P13 94	INT3945 ABG_M OW2	FOX_BR M_2.0	6CELL2. 4	3CELL2. 0H
TM3045WTM i	Middle East	TM3045WTM i XPPAR8 UMASC 1*1G/120/BT/ 6L+3H/5R/ CB_bg_1.3C_ _AL	C2DT72 00	N12.1 WXGA G	SO1G BII5	N	N120 GB5.4 KS	NSM8 X6P13 94	INT3945 BG	FOX_BR M_2.0	6CELL2. 4	3CELL2. 0H
TM3044WTM i	Middle East	TM3044WTM i XPPHAR8 UMASC 1*512/80/BT/ 6L+3H/5R/ CB_bg_1.3C_ _AL	C2DT56 00	N12.1 WXGA G	SO512 MBII5	N	N80G B5.4K S	NSM8 X6P13 94	INT3945 BG	FOX_BR M_2.0	6CELL2. 4	3CELL2. 0H
TM3043WTM i	Eastern Europe	TM3043WTM i XPPPL3 UMASC 1*512/120/ BT/6L+3H/ 5R_abg_VP_ 1.3C_AL	C2DT55 00	N12.1 WXGA	SO512 MBII5	N	N120 GB5.4 KS	NSM8 X6P13 94	INT3945 ABG_M OW2	FOX_BR M_2.0	6CELL2. 4	3CELL2. 0H
TM3043WTM i	Thailand	TM3043WTM i XPPTH2 UMASC 1*1G/120/BT/ 6L+3H/5R/ CB_bg_1.3C_ _AL	C2DT55 00	N12.1 WXGA G	SO1G BII5	N	N120 GB5.4 KS	NSM8 X6P13 94	INT3945 BG	FOX_BR M_2.0	6CELL2. 4	3CELL2. 0H
TM3044WTM i	Indonesi a	TM3044WTM i XPPHIN1 UMASC 1*1G/160/BT/ 6L+3H/5R/ CB_abg_VP_ 1.3C_AL	C2DT56 00	N12.1 WXGA G	SO1G BII5	N	N160 GB5.4 KS	NSM8 X6P13 94	INT3945 ABG_M OW1	FOX_BR M_2.0	6CELL2. 4	3CELL2. 0H
TM3044WTM i	Thailand	TM3044WTM i XPPTH2 UMASC 1*1G/160/BT/ 6L+3H/5R/ CB_bg_VP_1 .3C_AL	C2DT56 00	N12.1 WXGA G	SO1G BII5	N	N160 GB5.4 KS	NSM8 X6P13 94	INT3945 BG	FOX_BR M_2.0	6CELL2. 4	3CELL2. 0H

Model	Country	Description	CPU	LCD	DIMM 1	DIMM 2	HDD 1 (GB)	ODD	Wireless LAN	BT	Battery	2nd Battery
TM3044WTMi	Singapore	TM3044WTMi i XPPWSG21 W UMASC 1*1G/120/BT/ 6L+3H/5R/ CB_abg_VP_ 1.3C_AL	C2DT5600	N12.1 WXGA G	SO1G BII5	N	N120 GB5.4 KS	NSM8 X6P13 94	INT3945 ABG_M OW1	FOX_BR M_2.0	6CELL2. 4	3CELL2. 0H
TM3043WTCi	China	TM3043WTCi XPHSC7 UMASC 1*512/80/BT/ 6L+3H/ 5R_abg_1.3C _AL	C2DT5500	N12.1 WXGA	SO512 MBII5	N	N80G B5.4K S	NCB2 4X6P1 394	INT3945 ABG_R OW	FOX_BR M_2.0	6CELL2. 4	3CELL2. 0H
TM3043WTCi	Hong Kong	TM3043WTCi XPHHK9 UMASC 1*512/80/BT/ 6L+3H/ 5R_abg_1.3C _AL	C2DT5500	N12.1 WXGA	SO512 MBII5	N	N80G B5.4K S	NCB2 4X6P1 394	INT3945 ABG_M OW1	FOX_BR M_2.0	6CELL2. 4	3CELL2. 0H
TM3044WTMi	Thailand	TM3044WTMi i XPPTH2 UMASC 1*1G/160/BT/ 6L+3H/5R/ CB_bg_VP_1 .3C_AL	C2DT5600	N12.1 WXGA G	SO1G BII5	N	N160 GB5.4 KS	NSM8 X6P13 94	INT3945 BG	FOX_BR M_2.0	6CELL2. 4	3CELL2. 0H
TM3043WTMi	Thailand	TM3043WTMi i XPPTH2 UMASC 1*512/120/ BT/6L+3H/ 5R/ CB_bg_1.3C _AL	C2DT5500	N12.1 WXGA G	SO512 MBII5	N	N120 GB5.4 KS	NSM8 X6P13 94	INT3945 BG	FOX_BR M_2.0	6CELL2. 4	3CELL2. 0H
TM3043WTMi	Australia /New Zealand	TM3043WTMi i XPPAU1 UMASC 1*1G/80/BT/ 6L+3H/ 5R_abg_1.3C _AL	C2DT5500	N12.1 WXGA	SO1G BII5	N	N80G B5.4K S	NSM8 X6P13 94	INT3945 ABG_M OW1	FOX_BR M_2.0	6CELL2. 4	3CELL2. 0H
TM3043WTMi	Australia /New Zealand	TM3043WTMi i XPHAU1 UMASC 1*1G/80/BT/ 6L+3H/ 5R_abg_1.3C _AL	C2DT5500	N12.1 WXGA	SO1G BII5	N	N80G B5.4K S	NSM8 X6P13 94	INT3945 ABG_M OW1	FOX_BR M_2.0	6CELL2. 4	3CELL2. 0H
TM3045WTMi	Australia /New Zealand	TM3045WTMi i XPHAU1 UMASC 1*1G/80/BT/ 6L+3H/ 5R_abg_1.3C _AL	C2DT7200	N12.1 WXGA	SO1G BII5	N	N80G B5.4K S	NSM8 X6P13 94	INT3945 ABG_M OW1	FOX_BR M_2.0	6CELL2. 4	3CELL2. 0H
TM3045WTMi	Australia /New Zealand	TM3045WTMi i XPPAU1 UMASC 1*1G/80/BT/ 6L+3H/ 5R_abg_1.3C _AL	C2DT7200	N12.1 WXGA	SO1G BII5	N	N80G B5.4K S	NSM8 X6P13 94	INT3945 ABG_M OW1	FOX_BR M_2.0	6CELL2. 4	3CELL2. 0H
TM3044WTMi	Australia /New Zealand	TM3044WTMi i XPHAU1 UMASC 1*1G/160/BT/ 6L+3H/5R/ CB_abg_VP_ 1.3C_AL	C2DT5600	N12.1 WXGA G	SO1G BII5	N	N160 GB5.4 KS	NSM8 X6P13 94	INT3945 ABG_M OW1	FOX_BR M_2.0	6CELL2. 4	3CELL2. 0H

Model	Country	Description	CPU	LCD	DIMM 1	DIMM 2	HDD 1 (GB)	ODD	Wireless LAN	BT	Battery	2nd Battery
TM3044WTMi	Australia/New Zealand	TM3044WTMi XPPAU1 UMASC 1*1G/160/BT/6L+3H/5R/CB_abg_VP_1.3C_AL	C2DT5600	N12.1 WXGAG	SO1GBI15	N	N160 GB5.4 KS	NSM8 X6P1394	INT3945 ABG_MOW1	FOX_BR M_2.0	6CELL2.4	3CELL2.0H

Test Compatible Components

This computer's compatibility is tested and verified by Acer's internal testing department. All of its system functions are tested under Windows® XP Home, Windows® XP Pro environment.

Refer to the following lists for components, adapter cards, and peripherals which have passed these tests. Regarding configuration, combination and test procedures, please refer to the TravelMate 3030/3040 series Compatibility Test Report released by the Acer Mobile System Testing Department.

Microsoft® Windows® XP Pro Environment Test

Item	Specification
CRT Port Test	
CRT Monitor	View Sonic E72f 17" PerfectFlat color CRT Area with 1280*1024
LCD Monitor	COMPAQ FP 7317 17" LCD area with 1024*768 ACER AL722 17" LCD area with 1024*768 Gateway FPD1730 17"(1280*1024) CMV CM-930D 17" LCD (1280*1024)
Projector	BenQ FB8225 Panasonic PT-LC80U
TV	FERGUSON DV3 (QSMC) SONY Trinitron 14"VPL-CX5
Audio Jacks Port Test	
Microphone	SOMIC SM-001
Head Phone	TP-M06
USB Port Test	
USB 1.1-Mouse	Logitech Wheel Mouse(Optical, USB PS/2) HP Active Optical Scroll Mouse Microsoft Track Ball Explorer(USB PS/2) USB Stroll Mouse 2-button HM-28(Scroll, wheel) Logitech(Optical) Microsoft IntelliMouse Explorer 3.0 USB and PS/2 Compatible (Optical) (QSMC) Microsoft IntelliMouse Explorer 4.0 USB and PS/2 Compatible(Optical)(QSMC) Microsoft Optical Mouse Blue USB and PS/2 Compatible Logitech Cordless TrackMan Fx(Trackball, Optical) Microsoft Wireless Optical Mouse Blue(USB PS/2) Microsoft Wheel Mouse Optical(USB PS/2)
USB 1.1-keyboard	NewMen TECHNOLOGY Basic KEYBOARD HP USB Keyboard View Sonic UsB Keyboard Logitech Cordless Mouse and Keyboard(USB, Wheel) Microsoft Wireless Optical Desktop(USB PS/2) USB KeyPad:ZIPPY USB Keypad TK323(QSMC)
USB 1.1-Speaker	USB Mobile Theater-J1301
USB 1.1-FDD	TEAC FD-05PUB USB1.0 Device(QSMC) Panasonic YD-8U10 USB1.0 Device Mitsumi USB1.1 Floppy Disk Drvie(QSMC) SMSC USB1.1 external Floppy Drive(QSMC)
USB 1.1-Camera / CCD	Logitech USB1.1 QuickCam for Notebooks pro
USB 1.1-HUB	Slim DX-274AP USB1.1 SLIM HUB 4 Port
USB 1.1-Card Reader	IWILL 6in1 USB1.1 Card Reader/Writer HP USB 1.0 digital drive
USB 2.0-HDD	Hi-speed Certifies USB2.0 HDD NEWMAN USB2.0 HDD
USB 2.0-DVD/CD-RW	HP USB 2.0/Fire 4X/2.4X/8X DVD+R/RW Write

Item	Specification
USB 2.0-HUB	XHUB4 4-port USB 2.0 hub(adaptec) D-Link 4-Port USB 2.0 Hub Hi-Speed 4-Port USB 2.0 HUB(IOGEAR)
USB 2.0-Printer	Epson Stylus C65 Printer
USB 2.0-Handy Drive	Apacer
USB 2.0-Lan	Billionton USB2.0 10/100 Base Fast Ethernet
USB 2.0-Camera/CCD	Logitech QuickCam IM(USB2.0)
USB 2.0-Scanner	HP ScanJet 3500C USB2.0 digital flatbed Scanner(QSMC)
Bluetooth Mouse	Darfon Bluetooth Mouse (Ferrari 1000)
PCMCIA Test	
SCSI Card	Ultra Slim SCSI 1480B
Modem Card	Billionton Peripheral 56Kbps Fax/Modem PC Card Xircom CreditCard Modem 56-GlobalAccess
32 bit Lan Card	Xircom 32bit cardbus Ethernet II 10/100 D-Link DFE-690TXD 32bit 10/100Mb PC Card
1394 CardBus Card	Gppdvion PCMCIA convert to 1394 CardBus 2 Ports
USB2.0 CardBus Card	IOGEAR USB 2.0 2-Port CardBus Card INTOPIC USB 2.0 4-Port Notebook Card(CardBus)(QSMC)
Wireless Lan Card	3COM 11 Mbps Wireless LAN PC Card(QSMC) PLANEX 54 Mbps Wireless LAN PC Card LINKSYS Wireless-B Notebook Adapter(QSMC)
Wireless Lan AP	Intel 802.11B/G
Keyboard	ACER PS2 keyboard Logitech PS2 keyboard
Memory Card Test (SD/MS/MMC/SM/CF/Microdrive/XD)	
SD Card	Sandisk 256MB SD Card Simpletech 128MB SD Card Sandisk 1.0G SD Card X Digital Media SD 256MB Simpletech 512MB SD Card
MS Card	Sony 256MB MS Card (MS Pro) LEXAR 256MB MS Card (MS Pro) Sandisk 64MB MS Card
MMC Card	Transcend 512MB MMC Card
XD Card	OLYMPUS XD Picture Card 256MB OLYMPUS XD Picture Card 1G
SM Card	Apacer SM Card
CF Card	PNY Compact Flash 128Mb
Microdrive	IBM 1GB Microdrive

Microsoft® Windows® XP Home Environment Test

Item	Specification
CRT Port Test	
CRT Monitor	View Sonic E72f 17" PerfectFlat color CRT Area with 1280*1024
LCD Monitor	COMPAQ FP 7317 17" LCD area with 1024*768 ACER AL722 17" LCD area with 1024*768 Gateway FPD1730 17"(1280*1024) CMV CM-930D 17" LCD (1280*1024)
Projector	BenQ FB8225 Panasonic PT-LC80U
TV	FERGUSON DV3 (QSMC) SONY Trinitron 14"VPL-CX5
Audio Jacks Port Test	
Microphone	SOMIC SM-001
Head Phone	TP-M06
USB Port Test	
USB 1.1-Mouse	Logitech Wheel Mouse(Optical, USB PS/2) HP Active Optical Scroll Mouse Microsoft Track Ball Explorer(USB PS/2) USB Stroll Mouse 2-button HM-28(Scroll, wheel) Logitech(Optical) Microsoft IntelliMouse Explorer 3.0 USB and PS/2 Compatible (Optical) (QSMC) Microsoft IntelliMouse Explorer 4.0 USB and PS/2 Compatible(Optical)(QSMC) Microsoft Optical Mouse Blue USB and PS/2 Compatible Logitech Cordless TrackMan Fx(Trackball, Optical) Microsoft Wireless Optical Mouse Blue(USB PS/2) Microsoft Wheel Mouse Optical(USB PS/2)
USB 1.1-keyboard	NewMen TECHNOLOGY Basic KEYBOARD HP USB Keyboard View Sonic UsB Keyboard Logitech Cordless Mouse and Keyboard(USB, Wheel) Microsoft Wireless Optical Desktop(USB PS/2) USB KeyPad:ZIPPY USB Keypad TK323(QSMC)
USB 1.1-Speaker	USB Mobile Theater-J1301
USB 1.1-FDD	TEAC FD-05PUB USB1.0 Device(QSMC) Panasonic YD-8U10 USB1.0 Device Mitsumi USB1.1 Floppy Disk Drvie(QSMC) SMSC USB1.1 external Floppy Drive(QSMC)
USB 1.1-Camera / CCD	Logitech USB1.1 QuickCam for Notebooks pro
USB 1.1-HUB	Slim DX-274AP USB1.1 SLIM HUB 4 Port
USB 1.1-Card Reader	IWILL 6in1 USB1.1 Card Reader/Writer HP USB 1.0 digital drive
USB 2.0-HDD	Hi-speed Certifies USB2.0 HDD NEWMAN USB2.0 HDD
USB 2.0-DVD/CD-RW	HP USB 2.0/Fire 4X/2.4X/8X DVD+R/RW Write

Item	Specification
USB 2.0-HUB	XHUB4 4-port USB 2.0 hub(adaptec) D-Link 4-Port USB 2.0 Hub Hi-Speed 4-Port USB 2.0 HUB(IOGEAR)
USB 2.0-Printer	Epson Stylus C65 Printer
USB 2.0-Handy Drive	Apacer
USB 2.0-Lan	Billionton USB2.0 10/100 Base Fast Ethernet
USB 2.0-Camera/CCD	Logitech QuickCam IM(USB2.0)
USB 2.0-Scanner	HP ScanJet 3500C USB2.0 digital flatbed Scanner(QSMC)
Bluetooth Mouse	Darfon Bluetooth Mouse (Ferrari 1000)
PCMCIA Test	
SCSI Card	Ultra Slim SCSI 1480B
Modem Card	Billionton Peripheral 56Kbps Fax/Modem PC Card Xircom CreditCard Modem 56-GlobalAccess
32 bit Lan Card	Xircom 32bit cardbus Ethernet II 10/100 D-Link DFE-690TXD 32bit 10/100Mb PC Card
1394 CardBus Card	Gppdvion PCMCIA convert to 1394 CardBus 2 Ports
USB2.0 CardBus Card	IOGEAR USB 2.0 2-Port CardBus Card INTOPIC USB 2.0 4-Port Notebook Card(CardBus)(QSMC)
Wireless Lan Card	3COM 11 Mbps Wireless LAN PC Card(QSMC) PLANEX 54 Mbps Wireless LAN PC Card LINKSYS Wireless-B Notebook Adapter(QSMC)
Wireless Lan AP	Intel 802.11B/G
Keyboard	ACER PS2 keyboard Logitech PS2 keyboard
Memory Card Test (SD/MS/MMC/SM/CF/Microdrive/XD)	
SD Card	Sandisk 256MB SD Card Simpletech 128MB SD Card Sandisk 1.0G SD Card X Digital Media SD 256MB Simpletech 512MB SD Card
MS Card	Sony 256MB MS Card (MS Pro) LEXAR 256MB MS Card (MS Pro) Sandisk 64MB MS Card
MMC Card	Transcend 512MB MMC Card
XD Card	OLYMPUS XD Picture Card 256MB OLYMPUS XD Picture Card 1G
SM Card	Apacer SM Card
CF Card	PNY Compact Flash 128Mb
Microdrive	IBM 1GB Microdrive

Online Support Information

This section describes online technical support services available to help you repair your Acer Systems.

If you are a distributor, dealer, ASP or TPM, please refer your technical queries to your local Acer branch office. Acer Branch Offices and Regional Business Units may access our website. However some information sources will require a user i.d. and password. These can be obtained directly from Acer CSD Taiwan.

Acer's Website offers you convenient and valuable support resources whenever you need them.

In the Technical Information section you can download information on all of Acer's Notebook, Desktop and Server models including:

- Service guides for all models
- User's manuals
- Training materials
- Bios updates
- Software utilities
- Spare parts lists
- TABs (Technical Announcement Bulletin)

For these purposes, we have included an Acrobat File to facilitate the problem-free downloading of our technical material.

Also contained on this website are:

- Detailed information on Acer's International Traveler's Warranty (ITW)
- Returned material authorization procedures
- An overview of all the support services we offer, accompanied by a list of telephone, fax and email contacts for all your technical queries.

We are always looking for ways to optimize and improve our services, so if you have any suggestions or comments, please do not hesitate to communicate these to us.

